

TCR-100 Cartridge Tape System
Makes the Scene at WDCA-TV

Contour Enhancement . . .

makes your films and slides
look better



Matched TK-27 Color Film System . . .
now with the "live-like" quality of a TK-44A

The Contour Enhancement accessory for the RCA TK-27 Color Film Camera improves the TV picture by enhancing image edges, increasing overall definition. In addition, a special filter "combs out" the noise—permitting this improved performance without any increase in background disturbance. Thus film and slides will offer a new high level of picture quality. Even those not quite perfectly focused will produce better images on the TV screen. You'll get the same kind of sparkle and snap that you do from live pictures on the TK-44A.

When you use the complete RCA Color Film System your films come alive, they entertain more, educate more, they sparkle as never before. It's all due to a MATCHED system. The TK-27 Camera is the heart of the "matched design" system. Included is the Automatic TP-66 Film Projector, Solid-State TP-77 Slide Projector with preview feature, and new vertical-mirror-wipe TP-55 Multiplexer. All made by RCA, these units work together to produce the finest color TV pictures.

RCA Broadcast
Equipment

RCA Broadcast News

Published by RCA COMMUNICATIONS SYSTEMS DIVISION

CONTENTS

WDCA-TV: Scene of Cartridge Charisma	5
Madison Avenue Eyes the TCR-100	10
New Profits from "Off-Air" Production Facilities	16
All Girl Talk on Veracruz FM Duo	22
London Weekend Television	25
An Idea that Grew . . . at WOOD-TV	30
Solid State Multiplexer for Color Film Systems	34
Improving Reliability of TV Microwave	37
Products in the News	44

Copyright 1970 RCA Corporation, All Rights Reserved

Broadcast Systems Management Restructured to Changing Customer Needs

Organizational changes planned to strengthen RCA Broadcasting Systems to meet the demands of the 70's were recently put into effect by A. L. Hammerschmidt, Division Vice President.

"RCA Broadcasting Systems' management," Mr. Hammerschmidt said, "is keenly aware of its obligations to anticipate the evolving needs of our customers.

"In the 70's," he continued, "we see these needs taking two forms (1) constant improvement of equipments which affect on-air performance and (2) application of new technologies to systems that enhance the cost effectiveness of the broadcasters' operations."

Mr. Hammerschmidt brings to his post more than 35 years of broadcasting experience. He actually started to work in broadcasting (WBNS-Columbus) while still attending Ohio State University.

He began his career at RCA as a TV Engineer at NBC. His subsequent assignments included Assistant Director, Color TV Systems Development; Associate Director, Network Technical Operations and Vice President of Engineering and Facilities Administration.

Upon joining RCA Broadcast activity in 1966 he was named Manager of the newly created Electronic Recording Products Department. Before assuming his present duties he was Division Vice President of Broadcast Engineering and Product Management.

The restructured Broadcast Systems divides supervision of engineering and product management between Neil Vander Dussen and Carleton Musson.

Mr. Vander Dussen, as Manager of Studio Equipment Engineering and Product Management will have overall product responsibility for television cameras, TV tape recording systems, TV switching and control apparatus and related studio equipment used by broadcast stations and networks.

Mr. Vander Dussen recently returned to RCA after a year spent at the Massachusetts Institute of Technology as an Alfred P. Sloan Fellow. He received the degree of Master of Science of Management from M.I.T., along with 51 other executives from industry, business, government and education who completed the course of study.

After joining RCA in 1957, Mr. Vander Dussen became a broadcast salesman and was promoted to district sales manager. Later he held sales, product and engineering management assignments of increasing responsibility in various RCA Commercial Electronic Systems activities.

Mr. Musson is Manager of Transmitting Equipment Engineering and Product Management. His product responsibilities include TV, AM-FM transmitters, antennas and broadcast audio.

Mr. Musson rejoined RCA in March, 1970. Prior to that time he held a variety of posts with Wickes Industries, Inc., the last being Vice President of Planning and Development. His experience includes two stints in station operation, the last one being Chief Engineer of WJIM and WJIM-TV.

Another move brings Professional Electronic Systems into the Broadcast organization. This class of TV equipment fulfills the lower cost requirements for a segment of the Broadcasting Industry and has special appeal to closed circuit, educational and industrial markets.

Gordon Bricker, manager of Professional Electronic Systems based in Burbank, California, joined RCA in 1952 at Camden and during a five year tenure there held product management assignments in broadcast terminal and TV studio equipment. From 1957 to 1963 Mr. Bricker was a broadcast field salesman covering Colorado, Kansas and adjacent states.

Two key assignments in Broadcast Systems remain unchanged. Edwin C. Tracy continues as Division Vice President, Broadcast Sales in the domestic market and Joseph P. Ulasewicz as Division Vice President, Commercial Communications Systems International Operations.

Mr. Tracy joined the company in 1939 as a TV engineer for the RCA Service Company. In 1946 he was made sales engineer in Chicago. Four years later he became Field Sales Manager for RCA radio and television equipment. He was promoted to Division Vice President in 1964.

Mr. Ulasewicz started at RCA as a Trainee in Manufacturing and in his career he was an RCA Broadcast equipment field representative, Manager of Antenna Merchandising and, just prior to his present assignment, Manager of International Marketing for Broadcast & Communications Products.

John H. Cassidy (missing from photo) continues as Manager of Project Management and Administration Services. He directs a staff of systems implementation specialists who estimate, plan, manage and install complete Broadcast systems for the world market. He also manages the Custom Repair and Engineers shops.

Mr. Cassidy joined RCA in 1956 and prior to his present assignment was Manager of Sales Support and Services.

In conference (l. to r.) are Messrs. Musson, Vander Dussen, Bricker, Hammerschmidt, Tracy and Ulasewicz.



Traffic Flow Profile for Delaware Memorial Bridge

Vehicles moving across the twin 2,150-spans of the Delaware Memorial Bridge near Wilmington are being counted and their speed measured automatically by RCA electronic detection equipment installed as part of an advanced traffic control system.

The recently-completed system already is providing bridge police with a profile of traffic flow that enables them to regulate maximum speed limits and traffic lane use under varying conditions and times of day.

The 52 vehicle detectors, known as Ve-Det, used in the system operate from wire loops embedded in the bridge roadway at various points. A vehicle passing over the loop causes circuit changes, sending a signal to a roadside detector unit.

Two of the seven-foot-square wire loops, placed three feet apart on the upgrade of each of the twin bridges, detect the direction of traffic flow and the average speed of vehicles moving in each lane.

Speed is determined by recording the time required for a vehicle to travel from one loop to another. Speeds of a number of vehicles are averaged for a selected time period and the corresponding results are automatically re-

corded on strip charts.

Police also can determine the presence or absence of vehicles in any of the bridge's eight lanes by observing a control console. Indicator lamps on the console display a continuous picture of traffic and other events on the bridges.

When a lamp on the display panel glows, it indicates that no traffic has crossed over a selected detection point on the bridge for at least 90 seconds. This could mean a traffic stoppage and with the aid of closed circuit television, the police operator can investigate and dispatch a patrol car, tow truck, ambulance or other emergency vehicles as needed.

Other control panel lamps monitor toll plaza lane signals, aviation beacons atop the bridge's 440-foot towers, and traffic lane speed limit signs. Failure of a display panel lamp to light, for example, will indicate a beacon light was burned out.

The console also controls the illumination of various driver information and speed signs at the approaches to each bridge. Message signs have 24-inch letters reading: Slippery Roadway, Accident Obey Signal, Lane Change Obey Signals, Men Working, Fog Ahead, Snow, and Reduce Speed. Each sign is activated by a single pushbutton on the console.

Movie-Like TV Projection System in Development

Development of the first, practical, movie-like TV projector for possible use in home, school, defense and industry has been reported by RCA scientists addressing the 1970 symposium of the Society for Information Display.

The experimental projector is a greatly simplified, inherently low-cost system that employs an electron beam, a 500-watt light bulb and a special mirror to project enlarged TV images directly onto a 3 x 4-foot movie screen for general viewing. While considerable research remains to be done to raise the performance level of the new unit, its potential low cost and long life make such research worthwhile.

Heart of the new system is an extremely thin metal film, or mirror, that can be deformed electrostatically at TV speeds. Light from a very bright external source strikes the thin film mirror and is reflected onto a screen. The projected image is made up of reflections from the points at which the thin film mirror is deformed while its contrast is determined by the amount of deformation at each point.

The electrostatic deformation is accomplished through the use of an electron beam, similar to the beams that excite the phosphor screen of a conventional TV picture tube.

In present high-quality TV projection systems, an electron beam scans a thin oil film and the resulting deformations are imaged as bright spots on a screen by a bright light source, in much the same fashion. But such systems are quite complex and much too expensive for home use, costing \$30,000 or more.

Ground Breaking for Jersey Isle Plant Expansion

RCA recently broke ground on Jersey Isle in the English Channel for a new \$1 million plant facility that will permit expansion of the European commercial electronic activities established there four years ago.

The new structure, scheduled for completion within a year, will provide larger and more modern quarters for RCA's growing business in color TV tape recorders and other technical equipment for European broadcasters.

RCA Jersey Ltd., a subsidiary company, set up the present facility in a leased building to refurbish headwheel panels for RCA customers in Great Britain and Europe. The panel is one of the major components of the RCA color TV tape recorder and requires periodic reconditioning.

In the ground breaking ceremonies, Irving K. Kessler, RCA Executive Vice President, Defense and Commercial Systems, joined with Sir Robert LeMasurier, Bailiff for Jersey, and Patrick J. Murrin, Managing Director, RCA Jersey Ltd., in turning earth for the new 26,000-square-foot building. It will be constructed partially of native stone on a 2.6-acre site in an industrial park.

Mr. Kessler, noting in brief remarks that the ceremony occurred when so many other parts of the world were beset with economic problems, said the new facility was "a clear reflection of the confidence we have in each other, the cooperative spirit of your government and of the diligence with which all those involved in this project have performed their tasks."

Broadcasting's Technical Progress Tied to Adapting Developments In Other Areas

Broadcasting's technical progress over the next decade may well hinge on how effectively its equipment builders adapt the wealth of technology being developed in other areas.

Andrew F. Inglis, Division Vice President, RCA Commercial Electronic Systems, speaking before the Rocky Mountain Association of Broadcasters convention, said suppliers must search out usable technical developments in such fields as defense, space and computers where research expenditures are several times those in broadcast equipment.

He reminded his listeners—broadcasters from Idaho, Montana, Utah and Wyoming—that tapping this vast reservoir of technology along with the industry's own efforts can not in itself sustain technical progress in the broadcast industry.

"This progress can be likened to a three-legged stool, the legs being technology, economics and public policy," he said. "Major developments not only must be technically feasible but they must be economically sound and in accordance with public policy as defined by Congress and the F.C.C."

"With the tremendous amount of technology now available to us, it appears likely that considerations of economics and public policy will play a larger role in determining where we go from here."

Mr. Inglis' remarks formed the keynote for a program presented by a team of six RCA convention speakers who described new areas of technology which "we feel may influence deeply the future of broadcasting."

These areas included, among others, a survey of new developments in radio equipment, a review of progress and prospects for TV station automation and computer control, the promise and problems of cable TV, and communications satellites of the past and future.

In his remarks, Mr. Inglis noted that the broadcast industry has been built upon and its development heavily influenced by technological advances. As one example of rapid changes in equipment, he compared RCA's first TV tape recorder, the TRT-1, with the company's current TR-70 model.

The original unit had 150 electron tubes as active elements and required six full standard equipment racks in the station. By contrast, the TR-70 uses approximately 1,600 transistors—the equivalent of 4,800 tubes—and its cabinet packaging requires only half the space.

In RCA color TV cameras, the advance of technology has reduced weight and power consumption by nearly two-thirds. Camera size has dropped from 9.5 cubic feet to 1.2 cubic feet and normal studio lighting required from an average of 300 foot candles to 100. With all, the current TK-44A camera is cheaper than the original TK-41 model in terms of 1970 dollars, Mr. Inglis noted.

New Color TV Camera for Lunar Exploration

The Astro-Electronics Division is developing a space color television camera capable of transmitting pictures under all extremes of lighting on the surface of the moon—ranging from the dimness of sunrise to the brilliance of high noon.

The 10-pound camera being built for NASA is smaller, lighter, more rugged and more sensitive in low light levels than any color TV camera previously flown in space. It is immune to damage from sunlight, even when pointed directly at the sun, and can operate effectively across a light range much broader than that possible with previous space color TV systems.

Heart of the new RCA color camera is the revolutionary Silicon Intensifier Tube (SIT) recently developed by RCA Electronic Components, Lancaster, Pa. The imaging surface

of the SIT consists of almost 400,000 individual silicon diodes. The tube has a brightness magnification never before achieved in a color TV camera.

Besides its immunity to harm from sunlight, the SIT is highly resistant to damage from jolts or vibrations.

Normal TV tubes have a smooth imaging surface of photo-conductive material that can be burned by bright light or damaged by vibration. They also are not as sensitive to low light levels as the SIT.

The SIT also enables the RCA camera to provide fine detail on both very dark and very bright objects in the same scene—a capability not possible with previous tube technology.

Weighing only 10 pounds and measuring 4 by 6½ by 16½ inches, including lens, the RCA camera is designed expressly for use on future lunar missions and explorations.

Automated Programmers Allow NBC Radio to Advertise Regionally

Both WMAQ Chicago and KNRB San Francisco, owned and operated by NBC, will receive automated programmer systems from RCA. These systems, to contain tone sensing and switching circuitry, will allow NBC radio to provide regional advertising and announcements.

The equipment contained in the automated programmer systems include RCA type RT-25A Carousel Tape Systems, RT-25A Carousel Programmers (with 50-event capability), monitoring and line amplifiers, and silence sensor assemblies.

RCA Building Earth Resources Satellite Cameras

NASA has awarded RCA a \$9.2 million contract to build high resolution TV systems for two satellites slated to perform experimental surveys of the earth's natural resources in 1972 and 1973.

The Astro-Electronics Division, Princeton, N. J., will deliver two flight TV systems, each consisting of three return beam vidicon cameras, a control unit and a video combiner, for Earth Resources Technology Satellites (ERTS) A and B.

The systems will be primary sensors aboard the Earth Resources Technology Satellites. ERTS A and B may lead to orbiting systems able to map the entire world, spot blight in crops, catalog water supplies and chart pollution, find the best commercial fishing areas and produce other key natural resources information.

The cameras in ERTS will be the highest resolution TV systems ever flown in space. Each camera will employ about 4,000 horizontal scanning lines compared to about 1,000 scanning lines for the previous highest resolution in space TV.

The three cameras carried in each ERTS will all view the identical 100 by 100-mile ground area. However, each will image the scene in a different portion of the light spectrum—one in green, the second in red and the third in near infrared. The three images, after transmission to earth, can be combined into one color picture or can be studied separately.

The images will form an instant map of the terrain. Analyzed by scientists, they also are expected to reveal detailed data on such factors as vigor of vegetation, discharge of pollution into major bodies of water and oceanographic patterns that reveal the location of major schools of fish.

Since the satellite will pass over a given area about every three weeks, the images also will provide a means of detecting changes in such things as crops or water supplies.

ERTS A and B are slated to be launched in 1972 and 1973 respectively. Each of the satellites will be sent into a 570 statute mile, near-polar orbit.

KVIE Installs Butterfly on Existing Candelabra

Imagination coupled with the extraordinary characteristics of the Butterfly antenna enable KVIE to enjoy the benefits of operating from an existing 1500-foot candelabra.

At an elevation of 1,124 feet, the 3-layer Butterfly occupies space below the platform on the 12-foot tower faces previously reserved for several FM antennas.

Designed by RCA for Transtower, Inc., the candelabra supports the Traveling Wave antennas of KOVR and KXTV, and the Superturnstile of KCRA, and is located about midway between Sacramento to the north and San Joaquin Valley to the south.

The KVIE Butterfly generates a precisely shaped pattern with a peak gain of approximately 7, and permits the Channel 6 educational to achieve 100 kW ERP in both directions.

This is the fifth installation of the Butterfly, a newly developed panel TV antenna which offers these unique advantages: (1) The radiation pattern may be changed after the station is in operation. Therefore, KVIE at some future time could increase transmitter power and modify its antenna during off-air periods (such as overnight) to go omnidirectional; (2) the horizontal pattern performance of a Butterfly mounted on the faces of an existing tower is comparable to that of a free-standing antenna of other design; and (3) the Butterfly being mounted on the outside of a large tower is convenient to inspect and service. It does not hinder physical access to antennas mounted above it and in this case the elevator passes through the antenna.

WDBO-TV, Channel 2, Orlando, Fla., was the first to install the Butterfly, and is now adding an FM facility by triplexing. Others include WITV, Channel 7, Charleston, S. C., WMAQ-TV, Channel 5, Chicago, and the duplexed operation of DZAQ-TV, Channel 2 and DZXL-TV, Channel 4 in the Philippines.

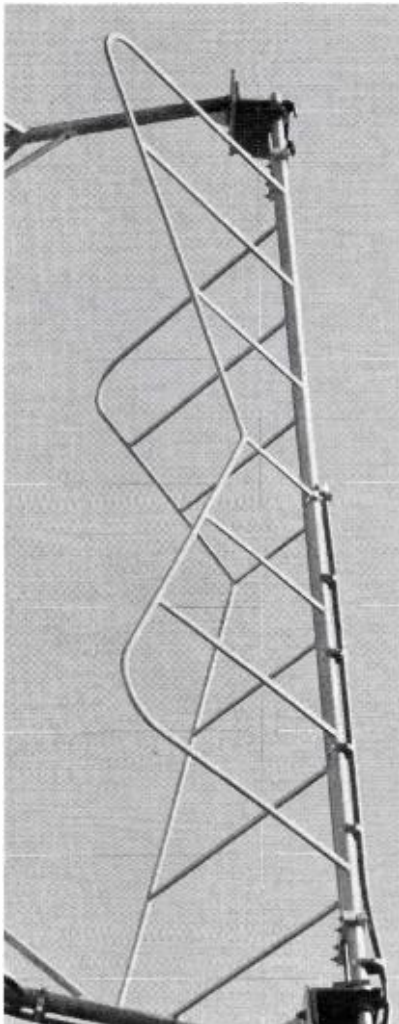

WDCA-TV: SCENE OF CARTRIDGE CHARISMA

WDCA-TV Reports on Reliability and Usage
of TCR-100 in 5 Months of Station Operations



ANOTHER NEW COMMERCIAL in WDCA-TV's expanding library gets the endorsement of Chief Engineer Don Doughty and Vice President, General Manager, Milton Grant.



Earlier this month Washington's independent UHF station, WDCA-TV, had reported more than 12,000 cartridge operations on their TCR-100 which had been in daily use since June.

Rarely does a single electronic equipment affect the daily job of just about every individual in a television station.

But such is the phenomenon at WDCA-TV, the independent UHF station in Washington, D.C. In a concerted effort to push WDCA-TV as far ahead in the technical field as possible, and to make it more than just competitive, General Manager Milton Grant, with an eye out for Television of the future, immediately visualized the cartridge machine to be as revolutionary as the audio-cartridge was. He wanted it. Then. Not later. This was during the NAB, 1969, when the machine was first introduced. NAB of 1970, cinched it. The station placed an order for the TCR-100 and it was selected to take part in the field test program using the pre-production model demonstrated at the convention. This equipment was delivered May 25 and after about a two week indoctrination and shakedown period, it was put into daily use.

The five month period has been characterized by change in station operations. The cartridge machine is handling all tape commercials and promos, while reel-to-reel machines have been turned over exclusively for presentation of syndicated tape programs and local production.

Economies Uniquely Fit Programming Plans

"Our programming goal, as we were planning to go on air last fall, was to schedule a 2½ minute break, including as many as five 30 second segments, to follow each 10 minutes of program time," reports Chief Engineer, Don Doughty.

"In planning the equipment to achieve this, we considered the independent UHF nature of our business and determined we'd need the equipment capa-

bility to handle as many as three tape segments in each break. This meant three tape machines. We were also very inclined toward local production and had planned two VTR's for that exclusive purpose.

"The mathematics were simple. We were going to need five reel-to-reel tape machines. That is until we got wind of the TCR-100. It could handle as many tapes as called for in all our breaks. And we could get two VTR's to handle production.

"When it came to savings, again the mathematics were simple. We were getting the value of five tape machines at a little more than the cost of three."

Thus the TCR-100 is equaling the productivity of at least three reel-to-reel machines at WDCA-TV. An examination of recent program logs reveals several occasions where five 30-second tapes have occupied the break. This could have taken as many as five reel-to-reel machines.

And A Whole New Thing

The number of reel-to-reel machines the TCR-100 can at any one time replace doesn't stop at three . . . or five. At WDCA-TV there are already plans to tape program intros and finishes, multi-slide ID's, bumpers—all the production enhancers that can and will fall into a short interval of time where it isn't possible to recue reel-to-reel recorders. As a bonus, this is new life for programs, new creativity in production.

With the TCR-100 to handle all tapes in the breaks, Program Manager Jim Reids' planning has become more flexible.

"Now I can look at the total station programming without being concerned with source

"Beginning this fall, on Saturdays, we'll be running twelve hours of video tape programs back-to-back. I don't think that I would have had the guts to do this without the TCR-100 handling all the tapes in the breaks. It does all that I expect from a machine. It just sits there and works."

New Business Reported

The money rewards of the TCR-100 didn't stop with the initial purchase of equipment. Sales Manager Dave Wygant credits the TCR-100 with enabling the station to take on production of a syndicated tape series.

"It's a strip series, requiring two full days of production each week. Without the TCR-100 automatically cranking out the commercials, we just couldn't have handled it.

"We can give the advertiser the time slot he wants, without having to consider whether his commercial is on film or tape or whatever. Production-wise he gets our uninterrupted attention. In fact, we're getting the reputation for being one of the most cooperative stations around."

Unexpected Speed in Dubbing

Dave O'Brien, Production Manager, comments on a "pleasant surprise".

"We were recently asked if we could handle the production of 100 dubs of a 30 second spot. On a reel-to-reel basis we weren't sure we were equipped to do this. And besides it's a costly, time-consuming process with all the repetitive cueing, setup, color bars, etc. However, I checked with engineering and discovered the TCR-100 could turn them out quickly. We dubbed a cartridge master which included color bars. We played this, making multiple copies on our reel-to-reel machines. The fast rewind and automatic recue features of the 'cart' machine turned out a hundred dubs, production-line fashion, in less than an hour. And the quality was excellent."

Based upon this experience, WDCA is engaged in soliciting more of this kind of business.

Promotion Program Breaking This Fall

"On-air program promos are essential to the independent station," Don Plumridge, Director of Creative Services for WDCA-TV, reports. "And we've logged a 30 per cent increase in the number of promos since our installation of the TCR-100.

"We produce all our promos on tape . . . it's easier that way. Before the Cartridge Tape Recorder we were limited, by the number of our reel-to-reel machines, to one tape promo in a break. This was frequently pre-empted. Because of the limitation all promos were 60 seconds in length. Now, with the added flexibility, we produce :30's and piggyback them. We plug more programs and get greater saturation.

"Furthermore, the TCR-100 has freed our reel-to-reel recorders for production. This gives us the opportunity to restyle all our promos for our big fall promotion. While we can't give the TCR-100 credit for inspiring this activity, it sure is helping to make it economically feasible."

The full program will call attention to the advertiser to an improved look and efficiency in program-

ming his commercial message, due to enhanced color and smoothness of presentation made possible by the TCR-100.

Exceptional Reliability, Consistent Quality

With the total tape library of nearly 200 commercials and promos on cartridge, certain operational problems have disappeared.

According to Les Corum, Operations Manager, "The one-reel-at-a-time limitations of reel-to-reel machines had created complex logistic problems, some of which had no solutions. With the TCR-100 we no longer worry about how much material in a single break or cut-in is on tape. We now can handle the Sales Department's time slot specification for commercials, and also meet some pretty tight deadlines on production jobs."

Commenting on reliability, Supervisor of Engineering Tom Morse was frankly surprised. "After a two-week shakedown, the 'cart' machine was performing with the same efficiency as our other equipment. Operators quickly developed a sure technique. Every morning the machine is cleaned and set up for operation within fifteen minutes. Cartridges are loaded, unloaded and changed with great dexterity."

There is increasing appreciation among the engineers and technicians for the opportunity the TCR-100 affords to perfect the presentation of the station's overall output.

Engineering Assistant Paul Weber puts it this way. "We've been able to take the time to optimize the output of commercial material. Each time we dub to cartridge, we can correct color and maintain a standard phase and saturation. Then once the machine has been set up right for one cartridge, it's right for all. We've been getting a lot of compliments on quality.

"We are averaging about 150 cartridge plays a day. A number of commercials have been played over fifty times, and some promos over a hundred . . . without any visible signs of degradation. They don't even look like they are starting to go."

Operational Plan

From the time WDCA-TV placed their order for the TCR-100, they began formulating a plan for integrating this new kind of equipment into their daily operations. Basically it called for familiarizing key department heads with what the equipment could do. This was accomplished by a trip to the 1970 NAB where the machine was put through its operational paces. Secondly, the decision was made to turn the machine over to engineering for an evaluation and shakedown period. At the conclusion of this period, implementation into daily operations could be achieved. And this would be followed by trade announcement and exploitation by promotion and sales departments.

First announcement of the station's acquisition of



EASY TO LOAD, as many as 22 cartridges can be stored in the magazine.

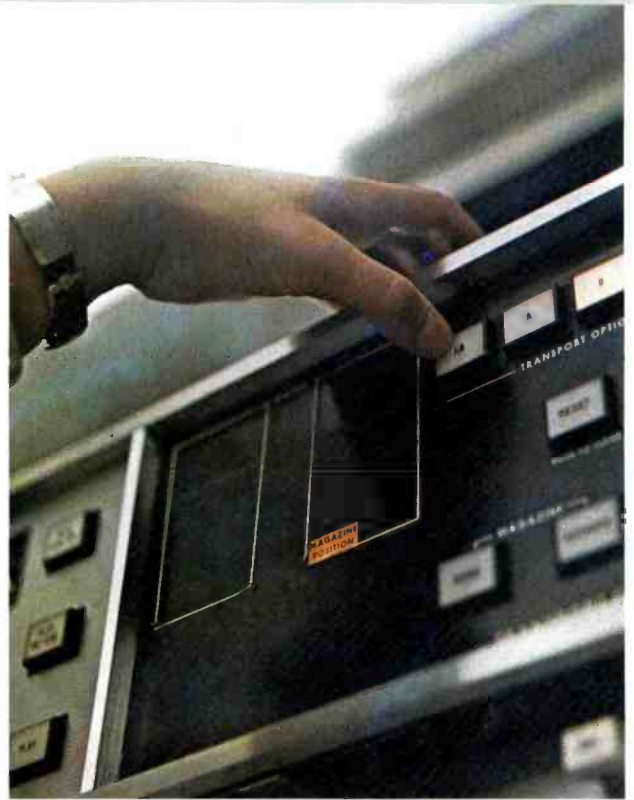

"WHAT'S HAPPENING" PANEL signals machine status as the operator makes ready for automatic operation.



LAST MINUTE CHANGE from traffic is handled easily. Cartridges are exchanged and the new commercial is ready to play.



WHIRL OF ACTIVITY, as cartridges are set in motion to make ready for the beginning of a program day.



GROWING LIBRARY of cartridge commercials and promos now numbers nearly 200.



COMPACT STORAGE permits locating a day's supply of commercials and promos closely.

the TCR-100 was made at a meeting of the Video Tape Production Association convening in Camden for a cartridge tape seminar. At that meeting, Milton Grant, Vice President and General Manager, WDCA-TV, spoke of the role of the video cartridge recorder in broadcast station operations.

He declared, "We expect the video cartridge will have the same profound effect on television as the audio cartridge has had on radio. It is certain to usher in a type of automation marked by a new order of quality, flexibility and smoothness of handling, all of which should enable us to serve our clients better."

Engineering Evaluation

The shakedown period was unexpectedly brief. Normally delivery of any new piece of equipment (especially one that portends a change in method of operation) is preceded by some trepidation. However, the TCR-100 won engineering acceptance in just two weeks. Certain minor problems, traceable to jarring which occurred in shipment, were quickly remedied, and the essential efficiency of the system became more and more apparent. Close study of the individual operating areas led to heightened appreciation of the design solutions.

During the two-week period, engineers were able to dub most of their inventory of reel-to-reel commercials and promos (a total of more than 180 tapes) to cartridge. From this point any new material was dubbed as required, scheduled easily within the normal production day.

With more than five months operating experience, station engineering is setting up preventive maintenance routines. No difficulties are anticipated. The machine already has attained the same order of reliability as any of the other equipment.

Sales and Promotional Exploitation

Before going into daily use, operations and traffic departments were alerted. Scheduling restrictions, pertaining to the number of tapes allowed in a break, were lifted. They were also notified of availability of reel-to-reel machines for production and playback of tape programs. And schedules were set up accordingly.

Sales and Promotion were advised and the WDCA-TV cartridge operation began to roll.

The station recognized the TCR-100 as a device with promotional appeal for both agencies and customers. Its on-air date was announced via a mailing of an RCA cartridge brochure accompanied by a letter of announcement.

Shortly afterwards, clients and agencies were invited to see the TCR-100 in action and be given a briefing on its implications and impact for them.

Salesmen were instructed on how the "cart" machine could be helpful in building more time sales and getting additional production work. Each salesman was furnished with a picture of the equipment and background information.

The campaign was on . . . calling attention to the improved color . . . the new smoothness and efficiency of commercial presentation . . . the new availability of production facilities.

A Vital Program Tool

The TCR-100 has become a part of the new spirit, a new image for WDCA-TV. It has had its effect on engineering, traffic, operations, sales, production, promotion, program, all departments. It has done everything it has been asked to do. It has made many jobs a little bit easier, and inspired new dedication to more profitable, higher quality operation.



THE PAYOFF is maximum use of facilities—active studios and cameras and uninterrupted use of reel-to-reel tape machines for production.



MADISON AVENUE EYES THE TCR-100 SYSTEM

For a number of years there's been speculation among advertising agencies on how nice it would be to produce and air TV commercials much the same as radio commercials; that is, in a cartridge. When RCA first demonstrated its TCR-100 Cartridge Tape Recorder at the 1969 Washington NAB, this wishful thinking turned to serious consideration in terms of both quality of presentation and the spiraling cost and complexity of distribution.

Through the agencies along New York's Madison Avenue (and Michigan Avenue and Main Street, USA) more than \$1.250 billion dollars annually is channelled into spot television buying.

An additional \$150 million (nobody knows the exact total, but the figure is a good guesstimate) goes into the production of television commercials—mostly on film, which is still the primary production medium of the TV commercials industry—for national and regional advertisers.

More millions of dollars are involved, representing the equipment and manpower of TV stations scheduled to transform the commercial from a silent reel of film or tape into a color-filled, emotion-rousing, sight-&-sound sales message on viewers' sets.

And yet . . .

When the Moment of Truth is at hand during a local station break Madison Avenue's TV practitioners—producers, media experts, creative staffers, editing and finishing experts, art directors, writers, account supervisors—have learned, the hard way, that they must be prepared to live with one of TV's most harrowing experiences:

The TV Goof-Up

The film spot whose every frame was fussed-over by experts until it was a model of technical cinematic perfection—that didn't run when it should have.

Or which ran when it wasn't supposed to.

The tape spot that was a mini-masterpiece of crisp color and rich sound—whose ending was clipped during a prime-time break in a prime market.

Program people aren't safe, either. Consider the exclusive on-the-spot interview with a famous statesman that never gets on the air during a newscast—because the film broke, or the wrong button was pushed. Or the closing credits that turn out to be those of last week's show.

When goof-ups occur on the commercial side of TV, a chain reaction of paperwork, make-goods, compromises, occasional arguments and late payments to broadcasters inevitably follows.

But the creative heart of a serious advertising practitioner or producer is seldom really mollified by the make-good system.

"We work so *hard* on our film commercials," a Cambell-Ewald (Chevrolet's agency) producer told BROADCAST NEWS in New York recently. "I like film. I think it's a great medium. That's why it hits me, personally, when there's an on-the-air mistake involving one of our film commercials. I don't think there's a production medium we'd prefer. But we'd certainly prefer to see the right film on the air at the right time in the right way."

Block Drug Swings To Tape

Video tape producers are, naturally enough, bullish about their medium. But Robert M. Ahrens, Adver-

"The next step, of course, is eventual completion of all film onto video tape without going through the film optical process."

Bob Ahrens



tising Production Coordinator of Block Drug Co., earlier this year, really made them sit up, at a meeting of the Videotape Producers Association. He revealed that Block Drug, a major television advertiser, had spent nearly four months of "careful investigation, analysis and much discussion," and had arrived at a new program to handle the distribution of hundreds of Block TV commercials on tape. He stated further:

"In spot use, we at Block provide each station with two or three 16mm contact prints of each commercial. Should we go onto another cycle, a second set of prints is sent. In tape, one dupe per station is sent for the life of the commercial."

Transferring finished film commercials to tape

would save a considerable sum, adman Ahrens estimated. Block executives like Alfred Plant, the firm's Vice President for Advertising and a longtime pioneer in adopting new media and broadcast techniques, "anticipate a savings of at least 10% against servicing the same requirements with film," he said.

Added Ahrens: "I think it will eventually come closer to between 15-25%."

"The next step, of course, is eventual completion of all film onto video tape without going through the film optical process."

"Even further into the future we get into cassettes—but that is getting way ahead of the game."

Video Cartridges Open New Horizon

The future arrived, however, much sooner than many advertising executives and production officials expected.

The RCA Video Cartridge Tape Recorder had made its debut at the 1969 NAB Convention in Washington, and immediately began causing a stir among station executives who saw it demonstrated.

By the time the 1970 NAB was held in Chicago, a number of broadcasters were already making plans to "phase-in" the new video cartridge tape system as a basic part of their station hardware.

Originally, much of the broadcast planning surrounding the new cartridge system was confined to the system's most obvious advantage—mistake-proof handling of the functions of conventional reel-to-reel tape machines, or a mix of VTRs and film chains.

But, as the TV industry has learned with every major broadcast hardware development, the application of new systems is often in directions the original system planners never anticipated. Call it American ingenuity, call it practical imagination, call it what you like. It happens for the same reason that Americans coax more performance from cars, boats, planes and other units than was originally envisioned.

Agencies, creative producers, program planners and syndicators, are beginning to eye the video cartridge recorder in terms of what it would mean to *them*. In production. In post-production. In program planning. In developing and formatting brand-new types of shows, which stem from the cartridge concept itself. In combatting the ever-encroaching, time-consuming "paper jungle" of reports and forms which has often threatened to engulf the spot TV industry.

Network Tape Breakthrough

Producing commercials on film and then "completing" or duplicating them on tape is not a new idea. But, more often than not, the process was something agencies held in reserve.

Saul Marcus, Supervisor for Commercial Production at Dancer-Fitzgerald-Sample, in fact, admits his agency viewed film-to-tape transfers as an aid in meeting "emergency situations when speed was essential."

But spot television has no corner on the additional

problems (and possibilities for quality drop-off, extra costs and human error) caused by the necessity of a multiplicity of commercial prints. The problems occur in network television, too, and tape is scoring new breakthroughs as a result.

Recently announced by Dancer-Fitzgerald-Sample is a new method of handling network film commercials for such advertisers as General Mills, Sterling Drug and Topper Toys. The system involved two years of study by Marcus, aided by Margaret Wagner, Manager of Radio-TV Services & Operations for D-F-S, and is now in effect.

Under the new network commercial plan, D-F-S film commercials will be transferred to tape, using (for the most part) 35mm optical negatives and magnetic tracks as the film source. The duplicating will be handled by Eastern Video Production Services, Inc., a New York City tape facility.

What changed D-F-S' mind concerning tape transfers of network film commercials?

D-F-S' Marcus explained it thusly to BROADCAST NEWS:

"In the past, there's been a lot of unnecessary 'warfare' in the industry over the merits of film and tape. It hasn't served either medium. But our study showed that a 'marriage' of these media made practical sense.

"In servicing networks with film prints for our clients, we generally have needed two or three high-quality prints, occasionally more, for each commercial, including those that are 'standby'. Until recently, individual film prints for network use were cheaper than individual tape duplicates.

"But there's little or no 'recovery' of film prints possible when film commercials are spliced into a network film show. And it's hard to avoid, occasionally, 'late charges' or extra handling charges with film commercials. With tape duplicates, since you need fewer copies for any one commercial and the tapes can be re-used, there's a saving. And with less money invested in duplicating, the client can devote more budget to production values."

Duplication of film commercials for spot television use by D-F-S clients continues to be on 16mm film. Whether this, too, will swing toward tape, and the tape cartridge concept, remains to be seen.

Philip McEneny, President of Eastern Video Production Services, the facility now responsible for duplicating the D-F-S network spots, points out, however,



"The cartridge system concept can be of real benefit to stations, and mean more income producing activity."

Philip McEneny

that his company is "exploring" quantity duplication of film commercials on video tape cartridges. "The cartridge system concept," he says, "can be of real benefit to stations, and mean more income-producing activity."

Wrong-Spot-At-Wrong-Time Problems

The "errors", goofs and other fluffs that are a normal part of the "panic period" of station-break operations are not simply a headache for station personnel, who are often trying to do two or three things at once, during break periods.

Major agencies with large broadcast accounts have long been aware of the problem, and have been more than receptive to new ideas and techniques to solve the problem.

George Simko, Senior Vice President and Associate Director of Media Management at Benton & Bowles, not long ago estimated that 46% of the spot invoices received at his agency showed "some kind of discrepancy."

By no means are such discrepancies a matter of minor billing errors.

A study conducted by Dancer-Fitzgerald-Sample, long a "major" agency on Madison Avenue, turned up the fact that among 1500 spot television discrepancies examined last year the spot was for the right client but for the wrong brand 14% of the time, and no less than 25% of the time was for the wrong client.

Agencies are joined in their concern by the new-breed media buying services which take on media-purchase chores for agencies which prefer to concentrate on conceptual and creative aspects of TV, or which act as an extension of the media-buying function of full-service agencies.

"As a buying service we are delighted with anything that reduces the chance for local-level error," Fred



"We would like nothing better than to be secure in the knowledge that what we have bought for our customers is what was delivered."

Fred Natters

Natters, Vice President of Timebuying Services, one of the largest and best-established firms of its type, told BROADCAST NEWS. "Agencies and clients tell us the parameters of their media plan—who they want to reach, how often, in what context, with what kind of efficiency. We buy it for them.

"It is obviously good business for us to be looking ahead to new buying assignments rather than looking back to correct possible mistakes. That's why we find the video cartridge concept an exciting one from our business standpoint. We would like nothing better

than to be secure in the knowledge that what we have bought for our customers is what was delivered."

Because of the enormous volume of television spot activity (one leading advertiser in the drug-detergent-cosmetic fields orders approximately 500,000 TV commercial film prints each year, and other giant advertisers are into similar figures) it is difficult even to stay on top of the make-good problem.

Agencies do not generally like to admit it, but if the paperwork (station invoices, chiefly) was checked on *every* TV spot—as opposed to the general practice of spot-checking in a regular pattern—agencies would need billing staffs three or four times larger than they have right now. Conversely, existing staffs would be adequate if the error factor was reduced.



"The TCR-100 has the potential of eliminating 25% to 30% of *all* the paperwork that station representatives handle.

Ron Krueger

Says Ron Krueger, an executive of the Harrington, Righter and Parsons station rep firm involved in both spot commercial and program activity:

"We've needed the video cartridge system for ten years. It ends the last-minute racking-up of commercials when station-break time comes along. The pre-loading capability of the TCR-100 is great. A station, whose TCR-100 set-up handles the commercials *knows* the scheduling is right.

"The TCR-100 has the potential, as I see it, of eliminating 25% to 30% of *all* the paperwork that station representatives handle. We would indeed welcome this. We are in business to sell local time and programs to agencies and clients who are getting more and more selective in their approach to TV marketing. We are not in the 'Error Business', with its piles of paperwork. And we don't want to be."

The Piggyback Plethora

The piggyback commercial—in which two :30s or even three :20s for different brands and products of the same advertiser are joined together to make a one-minute spot—has shown a geometric increase in recent seasons.

From the advertiser's standpoint, piggybacks are a way of holding the line in television. On rising media costs. On the upward spiral of talent payments. On steadily-increasing prices for production, finishing and distribution on film or tape.

As part of this trend, there has been an increase of something like 120% in the use of commercial ":30s" in the past couple of TV seasons. And, with the increase has come an increase in problems.

"Ninety per cent of today's piggybacks are coupled before they're ever sent to stations," says George Gould, President of Teletronics International, one of the busiest tape production facilities in TV.

"The cartridge concept in video tape is a definite step toward the release of *all* TV commercials on tape."

George Gould



"If they are film spots, there is a good chance they may have been done by different producers, and processed by different film laboratories—with the result being different color and sound values.

"The video tape cartridge concept is very, very exciting from this standpoint.

"If two or more film spots are to be coupled in a piggyback, the color can be adjusted in a tape transfer, and cartridges duplicated from this 'master'. Even if the spots are sent to stations separately, and coupled as piggybacks locally, not only can adjustment for color be handled but a far greater number of piggyback 'combinations' can be made.

"As we see it, the cartridge concept in video tape is a definite step toward the release of *all* TV commercials on tape."

The 'Quality Look' of Tape

When a film commercial is transferred to tape for mass distribution in spot TV, some significant points of difference between the resulting "tape spot" and the equivalent 16mm release-print spot occur.

For one thing, the transfer is usually done in a major production center like New York or Hollywood under optimum conditions. For another, the film from which the transfer, via film chain, is made is usually 35mm color with a magnetic track.

It is, in short, a "quality" picture-and-sound pairing, and the quality is transferred intact to tape.

Release printing for film commercials, on the other hand, is almost entirely handled on 16mm film, using reduction prints with optical sound.

As Teletronics' Gould sums up the difference between these two choices:

"When you think of the dollars spent to achieve a 'quality look' and 'quality sound' in film, and then consider that it is enjoyed mostly in screening rooms and not in actual on-the-air exposure because of the limitations of 16mm printing and optical sound, you realize something very quickly—transfer of an original 35mm film commercial to tape, and distribution on tape cartridge, is a real step forward for quality."

This view is shared widely in the TV commercials industry and along Madison Avenue. Its subscribers

"The cartridgeing of commercials on tape will be the major determining factor in the future distribution of commercials for TV."

Robert Winkler



even include executives in the film business in what, at first glance, looks like a form of heresy but which makes long-range business sense.

Robert C. Winkler, President of one of the largest post-production film organizations (opticals, prints, distribution, color correction, editing, etc.) in the field, VPI Services, told BROADCAST NEWS:

"I don't think the video tape cartridge system means an end to film as a production medium, by any means. Film will always be around. It has flexibility and familiarity important to many of the top commercial creators.

"The TCR-100, however, has solved the problem of *distributing* film commercials and providing an on-the-air picture and sound faithful to the original 35mm 'answer print'.

"The cartridgeing of commercials on tape will be the major determining factor in the future in distri-



"There is no bigger let-down than to see *your* commercial played from a 16mm print that's been badly treated."

Mel Sokolsky

bution of commercials for TV. In a couple of years I expect to see the industry change from film to tape as a distribution medium."

Mel Sokolsky, an independent and in-demand film commercial producer-director-cameraman whose credits include the award-winning "Gold Diggers" Contac spots, shares a growing industry concern about on-air commercial quality.

Admitting that his training as a still photographer makes him "a perfectionist," Sokolsky nevertheless feels that when he sees his own work on TV it is not always what he would like it to be.

"We all work hard at Sokolskyfilm to make every shot in every commercial we do 'just right,'" he says. "We work just as hard in achieving the right 'sound' for the voice track and music. There's no bigger let-down than to be out on location somewhere, tune in a local TV station in your hotel room when you're

trying to relax in the evening, and then see *your* commercial played from a 16mm print that's been badly treated. It's a traumatic experience."

"A technical development like the TCR-100 with its potential for transmitting to the viewer the identical color values and art values achieved with so much effort in the original film, is certainly a welcome sight in our industry."

Sam Magdoff



This view of Mel Sokolsky, primarily known for his creative live-action film commercials, is shared by Sam Magdoff, President of Elektra Film Productions.

Elektra is an animation production house, primarily, and one of the best-known in the industry. The firm's credits have long been oriented toward color quality on TV; they include, in fact, the production of the original NBC-TV animated "Color Peacock", possibly the most-played TV spot of all time.

Says producer Magdoff:

"'Color' quality in animation work is something we control to a very fine degree. It can be the whole point of an animation scene, or even an entire animated

commercial. It adds extra dimension, additional impact to the work of animation designers like Seymour Chwast, Milton Glaser, Fred Otnes and Peter Max.

"A technical development like the TCR-100, with its potential for transmitting to the viewer the identical color values and art values achieved with so much effort in the original film—let alone the protection against running the wrong commercial by accident—is certainly a welcome sight in our industry."

An Intriguing Future

Some of the possibilities and extra advantages of the TCR-100 system are only now being realized by the advertising and production industry.

Samples:

- Block Drug's Ahrens prophetically points out that "cartridge VTRs will undoubtedly free a lot of regular VTRs at networks and stations to do other things—like program production, program segments and local commercials."

- Harrington, Righter & Parsons' Krueger also predicts that widespread use of the TCR-100 will ease the problems of local-station production, enabling stations to build local shows with greater appeal to both the viewer and the spot advertiser. "We know, from talking with the stations we represent, that practically all of them are in a bind for local video tape

WHAT IT IS: The RCA Video Cartridge Tape Recorder is professional TV equipment of the first order. It represents—in a highly sophisticated way—many of the differences between reel-to-reel audio tape and miniaturized cassette tapes operating in a semi-automatic recorder/deck. First introduced at the 1969 NAB Convention in a prototype version, the new TCR-100 is a video tape system utilizing as many as 22 tape cartridges in two TV tape deck systems, one "playing" and one "standing by." The TCR-100 is both a recording and playback system. Tape used in its specially designed cartridges is standard two-inch quadruplex broadcast quality. It is designed to simplify TV broadcast operations, and to reduce human error to the vanishing point. Its application is principally in recording, programming, handling and on-air-playing of TV commercial or program material.

WHAT IT DOES: Any short-segment TV material—commercials, promo spots, IDs, program billboards and closings, news segments, etc.—can be recorded or transferred to cartridge tape. Original source is no problem; color film, live color, reel-to-reel color tape—all can be fed to TCR-100. From a color film chain. From studio cameras and associated switching and control equipment. From a standard reel-to-reel video tape recorder. It is then recorded and "packaged" for broadcast or studio playback. Segment lengths can be up to three minutes long, or as short as two seconds. TCR-100 cartridges can be pre-recorded in production centers like New York, Hollywood or Chicago, or recorded at local TV stations. The popular TV media practice of using "piggyback" spots is greatly simplified by the TCR-100; segments of piggybacks can be recorded on cartridges or spools separately, and the segments scheduled are "joined" (no need for splicing!) on the air.

HOW IT WORKS: The TCR-100 is "programmed" in advance to play a sequence of cartridges. A cue-up mode makes it

What Advertisers|Agencies|Producers Should Know About the RCA Video Cartridge Tape Recorder

facilities. Local newscasts on a New England station on our list, for example, tie up three film chains and two reel-to-reel VTRs during the show. It puts a real burden on the station's technical staff. The TCR-100,



"The TCR-100, actually, has provided the music and recording industry with a television medium comparable in opportunity to the playing of hit records in disc-jockey radio."

Len Stevens

however, will do a great deal to assist stations in such a bind." (Interesting Sidelight: a major network news series on NBC-TV faces the same problem on a larger scale; when the show is in run-through or on-the-air no less than 12 VTR's are completely tied up.)

● Brand-new forms of programming are already stemming from the TCR-100 system. In Philadelphia, the Vice President for Operations of U. S. Communications, Len Stevens, told BROADCAST NEWS of a new program service aimed at independent stations like those in the USC group, and tailored to TCR-100 capabilities: a new concept produced by Telejockey,

Inc. called *The Music Connection*.

"It will have a wide demographic appeal," he said. "It can be varied locally to reflect the pop music in each particular market because it will ultimately employ cartridge tape segments that use 'singles' records as the soundtrack. There will be live-action or special-effects visuals limited only by the imagination of the producer and the flexibility of the latest studio and control-room equipment.

"In other words, it will be contemporary pop music *radio* made into exciting, mind-boggling *video*. The TCR-100, actually, has provided the music and recording industry with a television medium comparable in opportunity to the playing of hit records in disc-jockey radio. What's more, we expect to see this form of programming—the TV disc jockey—become a major factor in TV tape syndication within 12 to 24 months."

What other new directions will the TCR-100 system create? What other effects will it have on the present methodology of production and distribution of TV commercials and programs? What will be its long-range effect on the advertising industry, apart from those already rapidly becoming fact?

Only time, and TV's well-known penchant for ingenuity, will tell.

But it's an extremely safe bet to predict that the changes will be numerous—and profound.

ready, and a single start command starts its operation. Cues are placed on the tape, automatically, when recorded. The TCR-100 reacts quickly; a fully synchronized color picture is available in two seconds from start-up, and changeover time between tape cartridges is a matter of microseconds. The cartridges themselves are carried in a rotating mechanism whose outward appearance is not unlike the oval of a miniature race-track.

HOW IT REDUCES HUMAN ERROR: The tape cartridges used in the TCR-100 are "keyed" so that there is only one correct way to insert them in the system. In each cartridge, the tape is protected from contact with the hands of operators, metal surfaces, etc. by metal "doors" that open to expose the tape only in the "play station" position. Notably reduced is the "human error" factor in which the wrong commercial is run by accident during a station break, or a film chain is put on the air when the origination should have been from a VTR (or vice versa), or the wrong segments are coupled during a piggyback spot. The TCR-100 can be programmed for airplay well in advance, when decisions can be made and concentration is possible.

HOW IT CUTS DOWN ON "EXTRA PRINTS": The usual practice of supplying TV stations with two 16mm contact prints of commercials or piggyback pre-spliced combinations (and sometimes three or more during a long-run campaign) is virtually eliminated by the TCR-100. No tape guiding elements touch the oxide side of the tape, making it virtually scratch-proof. Estimates are that the tape in each cartridge is good for about 200 "passes" with no significant reduction in quality. One film print (transferred by a TCR-100-equipped station to a cartridge upon arrival with the aid of a film chain), or one duplicate tape, is more than enough. Comparable savings to advertisers in network television are also possible through the TCR-100.

HOW IT IMPROVES THE 'LOOK' & 'SOUND' OF TV: Much of the "look" of a 35mm answer print in a screening room is reduced in quality, of necessity, during the usual post-production steps of reduction-printing to 16mm for quantity distribution and eventual airplay. A similar drop-off from peak quality of magnetic soundtrack is experienced in the optical, rather than magnetic, sound system of 16mm film. Repeated airplays of 16mm film do nothing to improve the situation. The TCR-100, on the other hand, makes possible the quality transfer of 35mm picture (or master tape image) to cartridge tape directly in a major production center for eventual distribution to stations scheduled to carry a spot TV campaign. It also can capture the original wide-range soundtrack of a commercial, and re-create it again and again on the air.

WHAT ITS LONG-RANGE EFFECTS MAY BE: The TCR-100's effect is already being felt in future plans for completion and distribution of film and tape commercials, both of which are easily transferred to tape cartridges. By reducing the possibility of human error during the "panic period" of station breaks and in-program commercials the TCR-100 also reduces the potential of make-good paperwork that inevitably follows in the wake of error, affording savings both to the broadcaster and to agencies and advertisers. From the standpoint of producers and commercial creators, the TCR-100 means that all the values of color, picture and sound inherent in the original finished answer print or tape master will be broadcast to TV viewers. And, as a bonus to both broadcasters and broadcast buyers the TCR-100 will "liberate" many productive hours of reel-to-reel video tape recorder time, and manpower.

(SPECIAL NOTE: For additional information on the TCR-100 or reprints of previous BROADCAST NEWS articles dealing with the new system readers may contact Editor, Broadcast News, RCA, Bldg. 15-5, Camden, N. J. 08102.)

NEW PROFITS FROM “OFF-AIR” PRODUCTION FACILITIES

One of the more exciting developments in the television station business is the trend towards fuller and more profitable use of off-air production facilities. More and more broadcasters are discovering the proverbial “Acres of Diamonds” in their own studios. They are finding themselves uniquely prepared—in both personnel and equipment—to handle the growing demand for production of commercials and syndicated programs. Advertisers and agencies are looking to the local broadcaster who can make facilities available and produce economically. It is here that station people attest to the value of the TK-44A Camera to make their job easier, making their tape production more dramatic and realistic, consistently producing a beautiful color picture even under adverse conditions.

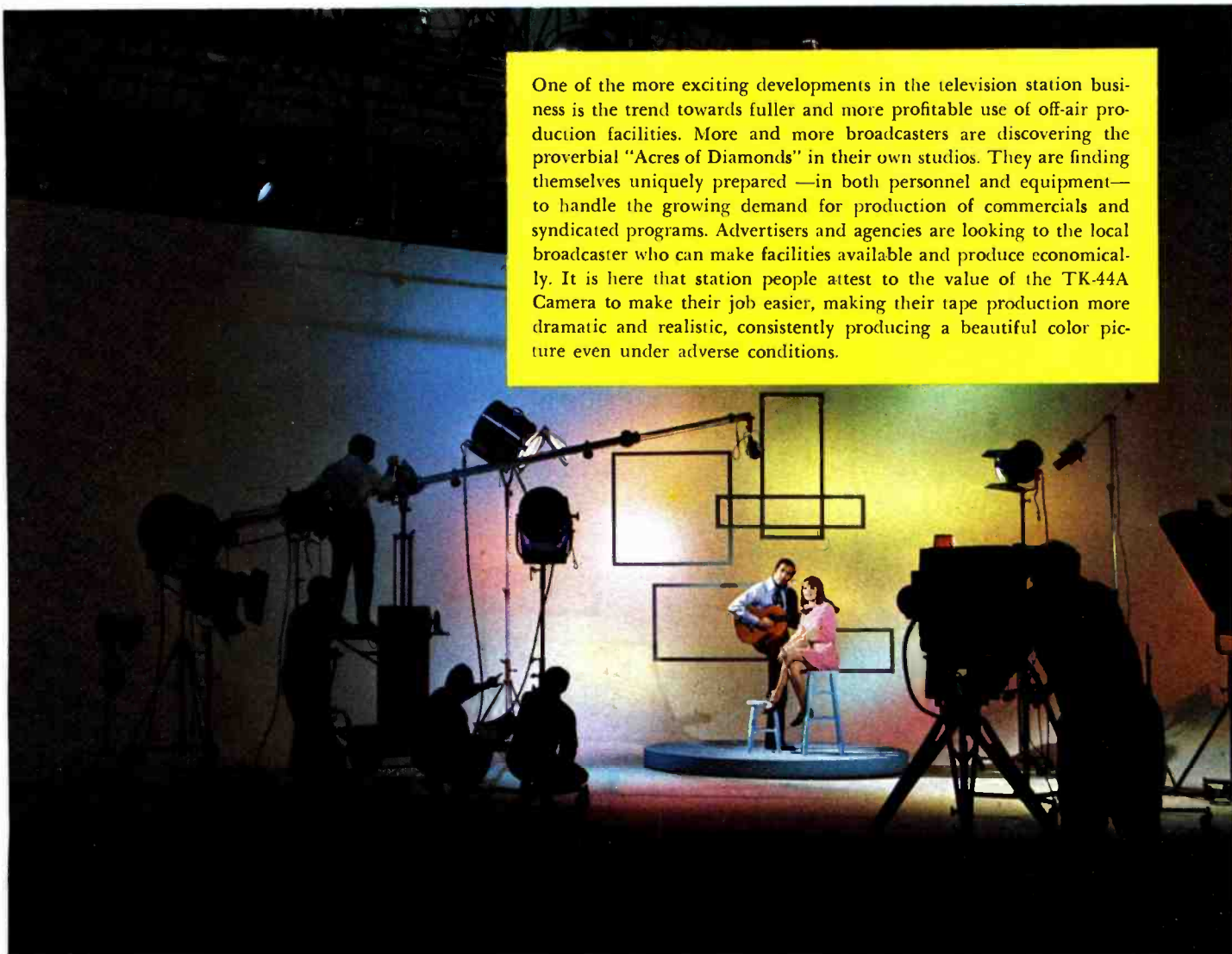

Our Arden Farms Commercial Received A Cleo Award

AL STEWART, Production Manager, KOMO-TV
Fisher's Blend Station, Seattle, Washington

KOMO-TV has long been noted to be extremely community conscious and we produce many local Public Affairs programs and public service announcements, but we are also deeply involved in commercial work. Our commercial servicing is one of the most complete in the Pacific Northwest, employing seven Director/Producers, and four Producers/Writers, augmented by Production Assistants. (Total personnel in Production Department number 55.)

Much of our commercial work is requested through the locally based agencies, but "direct accounts" are an important part of our commercial production. For the "direct accounts", we act as agent and producer. This has been of great assistance to our Sales staff in contacting people who lack advertising experience in the media.

Many of our sales are based on the ability to produce. Larger advertising agencies are now coming to the local station for commercial production rather than jobbing it out to major production centers. Economy has a certain effect, but I feel that the addition of more sophisticated electronic equipment by our station is most influential. Certainly the TK-44A Cameras have given us a decided advantage in color commercial productions.

We deal with approximately 150 commercial customers per year and we work with around a half dozen accounts every week within our studios. Last week, for example, we produced 18 spots for one account. Since Seattle is not recognized as a production center, the majority of our work is for local customers. However, we are called on by agencies located in other parts of the country to provide production services for locally based accounts. As an example, we have produced Montgomery Ward commercials which were used throughout the West and Midwest.

To say that the TK-44A is superior would be a gross understatement. Although we have pioneered color in this area, the TK-44A opened a new door for us. The effects and sharpness as well as the versatility of this camera have been a delight to our engineers and production staff, and has had a tremendous impact with our customers. One of the great advantages is its ability to handle abstracts in lighting and chroma key effects. It's a very simple process to set chroma key backgrounds and our customers are amazed with the effects that we can achieve for them, combining the versatility of the camera and video tape.

An example is a 30-second commercial for Arden Farms, which received a 1970 Cleo Award. It was in behalf of a Seattle based agency, Cleveland & McKeen.

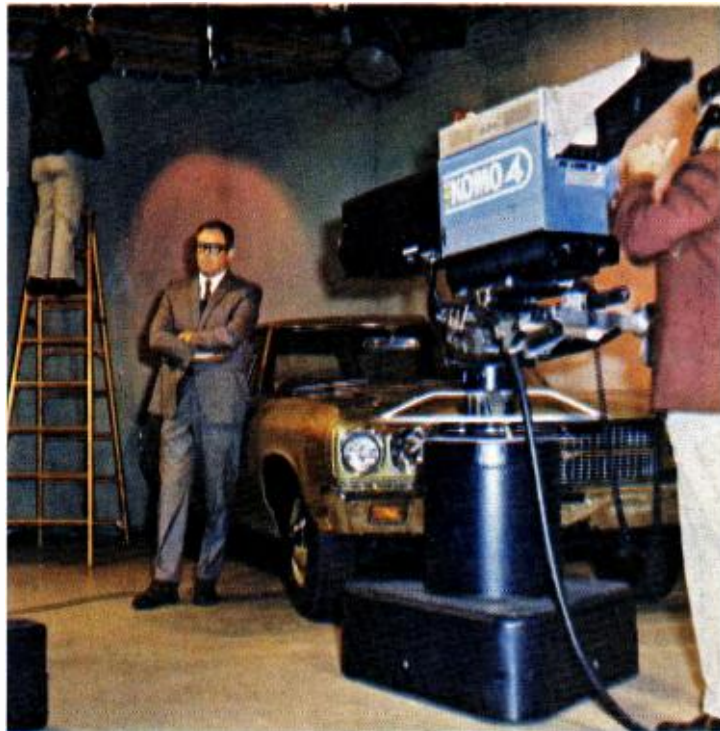

In August 1969 we purchased from RCA, a custom designed, self-contained, 35-foot mobile van equipped with TK-44A Cameras. This past winter and spring we were involved approximately twice a month in contract work utilizing our Mobile Video Center. In many cases we worked with other Network units, providing additional equipment. We have originated football and sporting events for the ABC-TV Network, and basketball games for the TVS Network. We anticipate an even greater use of our equipment in the sports seasons coming up. An interesting remote situation will occur in the Spring of next year when we will provide cameras and tape facilities for the Washington State Dental Association Convention and produce three programs dealing with dental surgery to be presented to the Convention via closed circuit.

We were the first and are the only station in the Puget Sound/Western Washington area, to have the TK-44A Cameras. We have used these cameras throughout the area with our remote pick-ups and at every origination were complimented on the clarity of the picture and the effectiveness of the cameras. We have received many compliments from the ABC-TV Network and other independent stations who have carried our originations. KTLA in Los Angeles commented, following our origination of a basketball game in Oregon, that they were getting the finest pictures that they had seen from a remote. We at KOMO feel a great pride in having and using the TK-44A. We have four of these fine cameras and our only regret is that we don't have four more.

We Offer A Total Package: Product Study, Production, Air-Time

DON PLUMRIDGE, Director Creative Services,
WDCA-TV, Channel Twenty, Inc., Washington, D. C.

At WDCA-TV we have several things going for us that make a hit with clients—and agencies. We can offer the most available production time and fastest commercial production services, evident by the fact that about half of all production in Washington is done at WDCA-TV. We offer the finest color camera and most sophisticated VTR equipment.

Quite frequently this is the client's first exposure to

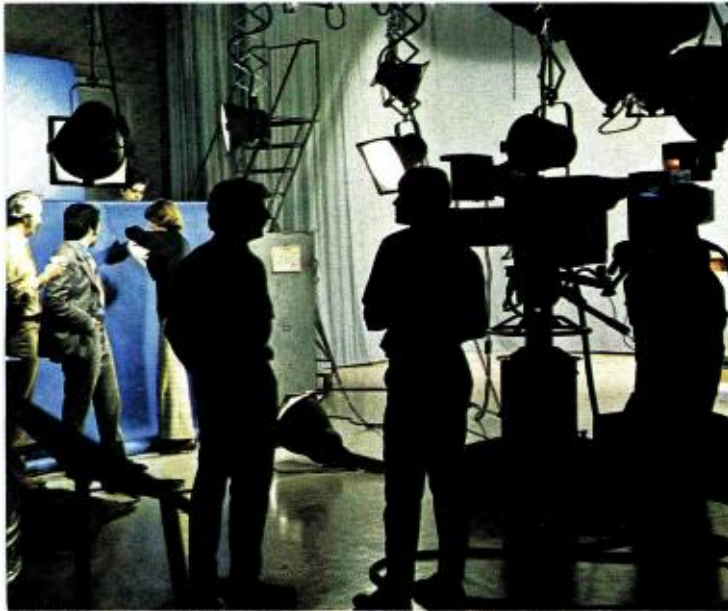

competitive UHF television. When dealing with clients and producing their commercials, we can sell them on both the production and advertising aspects of their investment. We offer a total package—we study their product, produce a commercial for it, then air that commercial. Our sales staff emphasizes the quality, economy and cooperation which are afforded by our station. From a technical standpoint we have the finest facilities, the best available equipment. We planned it that way. We wanted to become the number one commercial facility in our town. On the other hand our cost for these excellent services are below competition.

Our Production Department includes two Producer/Directors, 4 Writers, 3 Artists/Set Designers and a 3-member Creative Service group plus Executive Producer with various assistants and specialists. We have

some 125 commercial clients for whom we produce approximately 700 commercials in a year's time. About 90 per cent of these are for local-regional market use. Locally based advertising agencies account for a substantial portion of our larger accounts. Our retail sales staff deals with local clients and agencies directly. The total sales staff includes a General Sales Manager, a National Representative, four Account Executives, three Local Retail Salesmen. In addition, we have a Production Sales Manager who sells our production services direct.

We have four TK-44A Color Cameras and are able to maintain a high degree of confidence in the regular performance of the cameras for quality commercial products. While many customers do not understand the technical aspects, they can easily see why it is that the TK-44A has a reputation for quality.

We use the TK-44A to produce one of our syndicated shows, "Heavyweight Wrestling" at National Arena. Here it is particularly valuable, as lighting conditions are dreadful and production would be impossible were it not for what the TK-44A can do. Even under the most adverse conditions, the TK-44A produces high quality color.

It's a great feeling of pride with us to have the satisfaction that we supply the most sophisticated technological developments in the TV industry to our clients. We have the first VTR Cartridge machine in the history of broadcasting in field test operation at WDCA. This assists in on-air production, in playing commercials, promos, PSI's—anything—at station breaks. It's done automatically, there's no chance for human error. Literally, the TCR-100 takes over the tape air function, which normally tied up three color VTR's. Now with more production time available this machine gives us a competitive edge.

We Capture on Tape The Subtleties Unattainable in the Past

PHIL A. SAMUELS, Production Services Director
WTMJ-TV, Milwaukee, Wisconsin

Many agency producers have criticized television as a production medium because of what they call a harsh "tape look". They have described the look of tape as "brassy", "fake", "obviously done in a studio". They say pictures they have seen on tape lack subtlety. They say that it has been difficult to attain dramatic effects and difficult to convey emotion.

Since installing the TK-44 Cameras, we have been able to change some thinking in this regard. The drama, the emotion, and the subtleties that have seemed unattainable on tape in the past, are more often a function of lighting practices, equipment, and the camera, rather than the tape itself. With the TK-44



and its greatly increased signal-to-noise ratio, less light is needed under normal conditions. Working with less light, most situations are easier to control.

For special dramatic situations, such as a living room that appears to be lit only by the light of a television screen, or a fruit bowl under a table lamp, the TK-44 and the improved lenses make these effects manageable and believable to the most discriminating audience and agency producers. We have developed product shots under nine foot candles, with perfect color rendition, no smearing and with no noise in the shadow areas. Rear screen and front projection are very practical.

We are using soft light gear for product and display scenes and are rendering all of the subtleties that this type of gear implies.

The image enhancer allows for adjustment to make certain scenes snap and sparkle, while affording the option to soften and mellow other low key scenes.

And the TK-44 is light and maneuverable. The Houston-Fearless counter balanced pedestal can again be used. Our Directors are again calling for dollies, trucks, arcs and pedestal movement on the air.

And my engineering associates would hasten to point out the quick set-up and alignment features of the TK-44. When I move a crew from one Studio into another, it takes less time to align the cameras, than it does for my director to get a cup of coffee.

WTMJ-TV Programming and Production has on staff six Producer-Directors, a Copywriter-Production Assistant, and a Cinematographer. About 40% of our time is devoted to commercial production. We do work for about thirty-five different agency clients in a year's time. Most of our clients are local, however, we do work periodically for national accounts. Presentations for specific projects are made by myself and all of our sales staff. We have available a brochure describing the services and staff of Innovision IV.

We Originate For ABC, CBS, CTV and NBC Networks

B. J. BILLO, Program Manager, CFTO
Baton Broadcasting Limited,
Toronto, Ontario, Canada

Glen Warren Productions Ltd. is a commercial production arm of Baton Broadcasting Limited and leases facilities through Baton Broadcasting Limited as required. Glen Warren Productions Ltd. spent about 25% of its time on commercial productions and 75% of its time on syndicated program productions. The 162 employees in the production and services departments and the 55 Producer/Directors and creative staff annually produce 500 commercials for 50 national customers. With sales offices in Toronto, Montreal, New York and Detroit, we obtain work through both local and national agencies.

The sharp, clear picture and effective operation under lower light levels has been of substantial benefit to the station. Because of these facts, the 44A is a desirable camera for commercial and syndicated productions. We have a mobile unit which can be equipped with six TK-44A's and when combined with a separate unit containing two tape recorders we feel we have a quality mobile operation for remote production.

For example, we have done many crusades for Billy Graham and have just completed coverage for ABC of the Can-Am Mosport Race in June of this year. We originate N.H.L. Hockey for the CTV Network on Wednesday nights from Toronto throughout N.H.L. season and football as required from Toronto and Hamilton for the CTV Network. In addition, we have originated and fed football and hockey for NBC and CBS.

We have assembled an air package with special mounting and racks which is independent of our mobiles and last year we transported five 44A's complete with VTR to Australia to cover the Billy Graham Australian Crusade.

We have produced many syndicated programs here at CFTO, the most recent of which is "Andy Williams Presents the Ray Stevens Show" while at present we are producing the syndicated Barbara McNair series.



We Work With 150 Clients And Produce 750 Commercials Yearly

RICHARD BICE, TV Production Supervisor
WBAP-TV, Ft. Worth/Dallas, Texas

WBAP-TV engages extensively in production of commercials, occasional syndicated shows and quite a few mobile remote location pickups. Seven Production people are engaged in the operation, offering a full range of services: writing, set design, lighting plus creative planning and execution. In this activity are engaged four Producer/Directors, a creative writer, set designer and an artist.

Commercial production takes about 24 hours weekly. Of course when we do syndicated shows, films, or location video taping this jumps up considerably.

We work with probably 150 commercial customers yearly and produce approximately 750 commercials. These are all local accounts. Approximately 35 per year are national accounts.

An agreement has been reached between WBAP-TV and the firm of Keitz and Herndon for the production of film and video tape spots and programs. The combination of Keitz and Herndon's studios and WBAP's remote truck promises to be highly advantageous to advertisers who utilize these services.

According to Jett Jamison, WBAP's Director of TV Operations, "With the creative abilities and produc-

tion techniques of Keitz and Herndon and our remote unit we will be offering a new dimension to the production services available in the Dallas-Fort Worth area." Larry Herndon and Rod Keitz, commenting on the agreement, said "From our point of view as producers, it will enable us to keep abreast of the full spectrum of communications."

Our remote unit is equipped with six TK-44A Cameras and two TR-70 Recorders. We do contract work for video taping and live coverage. We have used the TK-44A Cameras on location for production of commercials for clients such as Department Stores, Food Chain Stores, Banks, and local public service activities.

On location at a school when video taping for a bank the TK-44A Cameras performed excellently. They required less light in classrooms and hallways. Their small size was most helpful in moving through the building. Our customer was well satisfied in production and quality of picture produced from the TK-44's.

We have found that the TK-44A is helpful in selling our station facilities for commercial production. We always feature them when we seek production work in the studio or on location.

Makes Our Job of Selling Easier

WILLIAM G. MOLL, Operations Manager,
WSMW-TV, State Mutual Broadcasting Corp.,
Worcester, Mass.

As a new station on the air only since January, we are still experimenting. We have found that commercial production is a necessity in our community. We are the only TV station in Worcester; ad agencies and clients have few or no ready made spots to air. The result is that we produce for them. Fortunately for us the TK-44A's made our job easier and the results all the more gratifying.

In the Production Department we have 21 people: Production Manager, Producer/Directors, production crew, Writers and film specialists. There are four full time producer/directors, plus three part-time directors working on weekends and various replacement hours.

Our three-man Continuity group spends full time in writing and production of commercials. Normal studio crew time for production of commercials is 4 hours per day, 3-4 days weekly. Frequently crews are called in for weekends and for an additional 6 A.M.-



2 P.M. shift to meet special client needs or deadlines.

Although a scant ten months old, WSMW-TV has more than one hundred clients. Most are local or regional, with emphasis on local production. Both locally based agencies and regionally based agencies make use of our plant.

The Sales Department has been instrumental in promoting use of our facilities. Tours are set up for clients as well as for agencies. During a tour a sampling of commercials produced by the station is screened. In-

quality created by the cameras gave the final film product an exceptional quality, both in resolution and, perhaps more importantly, in chroma. In another example, the client required a high volume of commercials (forty 60-sec. spots). The short set-up time of 44's made it possible to produce in larger quantities.

Furthermore, the TK-44A's have had several unusual tests of their ability to perform at low light levels. A basketball game, for instance, in a gymnasium utilizing fluorescent lights and a candlepower of

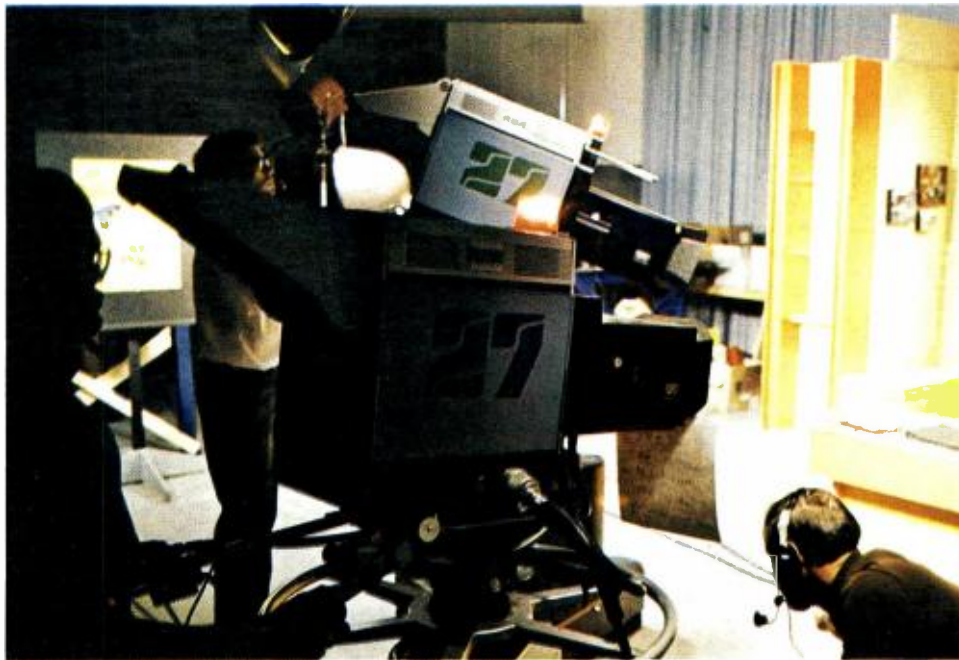

terested clients then consult with Continuity about how they can effectively employ our production facilities.

Because Worcester had limited access to television advertising, local advertisers and agencies were not set up for production of commercials. Opportunity thus presented itself for an extensive familiarization process between station and clients/agencies. This had a distinct impact upon the demands for commercial production time as well as air time. The fact that the physical facilities are of the finest RCA design and quality enhances our ability to serve the client.

Performance of the TK-44A Camera is crucial to the effectiveness of the commercial and the satisfaction of the customer. For example, we solved a unique commercial problem as a direct result of the TK-44A's. This client required tape-to-film transfers. The chroma

less than 50 footcandles looked like a sure set up for black and white. But the TK-44A's surprised everyone with remarkably good quality, high resolution, color pictures.

A state political convention in a field house of the University of Massachusetts with severe lighting problems was similarly dealt with by the cameras. Our remote unit was used as the pool feed to five stations. The result was highly satisfactory.

A remote at a hospital, working with available light, was likewise dispatched: Excellent color quality, short set up time, high resolution, and excellent reliability.

Covering a golf tournament play off on a morning's notice was possible only because of the short set up requirements of the cameras.

Having the equipment that does the job makes our job of selling services easier.

IT'S ALL GIRL TALK ON VERACRUZ FM DUO

Prepared by ASTRID HAGENGUTH

THE TRUMPET in the station's logo represents music, and the three fish, the Port of Veracruz.

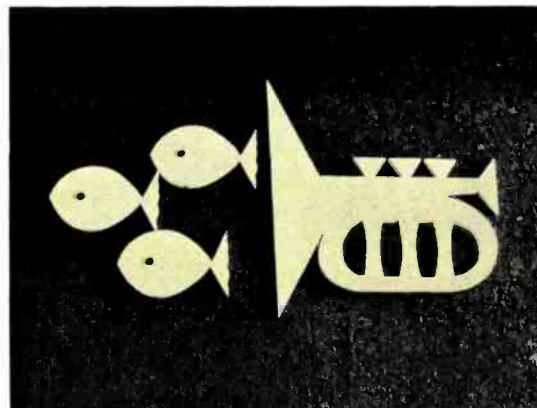

FISH EYE VIEW of control room for XHPB-FM.





DISTAFF SET handles all production operations.

As long as he was building one FM station, he figured he might as well build two and have a set. Felix Malpica Mimendi's new FM duo and his all-girl broadcasting staff in Veracruz, Mexico, are trend-setters any way you look at them.

All RCA-equipped, the two stations are quite possibly the best and most modern in all of Mexico. Men's voices are rarely heard. Female personnel are used as announcers, and girls handle all production operations.

The stations are situated in extremely compact office space on the top floor of a new six-story office and mercantile building three blocks from mid-town Veracruz. The transmission tower and antenna are on the roof directly above.

Station XHPB (stereo, and under 10,000 watts) is on the air from 7 a.m. to 1 a.m. concentrating on a general audience with movie themes, instrumental arrangements of pop tunes and semi-classical selections.

XHPR (monaural initially, at 20,000 watts) will aim at the important youth market and young adults with pop music, including rock, blues and soul.

Up to now, the six local AM stations have only offered Mexican folk-type music with little variety, and flood their programs with commercials. By launching his two FM stations in combination, Mr. Malpica hopes to discourage competition and is also in a position to offer attractive package deals to advertisers.

Mexican FM stations are allowed to carry two commercial spots to every three musical selections. As of May, the second month of operations, XHPB advertisers had purchased spots at the rate of \$3,200 monthly.

Radio, First in Communications

Radio is the most important communications medium in Mexico, with an average of three listeners per set. In remote areas, the radio often holds an honored

spot in the general store or other public place where villagers gather in the evening to listen to news and music.

There are about 10 million radios, 496 AM and 37 FM stations, as compared with 2.3 million television sets and a national network of 34 TV stations, plus 43 local channels. In the metropolitan areas, 30 to 40 per cent of the radios are operating at any given moment during the normal listening hours. Although they have a high readership per copy in the cities, Mexico's 265 newspapers only have a circulation of about 5 million.

Combined Staff

In Veracruz, a major seaport and air center with a population of 242,000, there are six AM stations and one television station. Mr. Malpica was formerly associated with the one newspaper, *El Dictamen* (circ. 25,000). He also owns a cemetery and serves as a revenue inspector for the federal government.

In addition to Mr. Malpica, the president and program director, and his son who is general manager of the combined stations, the staff includes a chief engineer, four girl control room operators, two production girls and two secretaries. Five salesmen cover the state of Veracruz, a long, narrow area stretching for some 400 miles along the Gulf of Mexico.

There are also eight technicians for installation of the stations' auxiliary commercial music service. Three hotels have already signed contracts for approximately \$1,000 U. S. currency monthly.

All Cartridge Operation

Programs for both stations, along with commercials, DJ's commentary and station IDs, are taped on cartridges. The stations carry no live production, although microphones in the control rooms would permit live broadcast in an emergency. All music is taped

PRODUCCION



PRESIDENT and program director,
Felix Malpica Mimendi.



RECEPTION AREA, with door to the production room. The two control rooms, transmission room and general manager's office are opposite the reception desks.

from records selected in local record shops and from working tapes, many obtained from Altophonic Tapes Inc. of Hollywood. International Good Music supplies tapes for the stations' commercial music systems.

Floor space is divided into a reception area, an office for the general manager, a production room and transmission room serving both stations, and a control room for each. The production room can feed either transmitter directly in an emergency and serves as the master control room.

The flow and mutual access in such a compact area makes for great simplicity and efficiency of operation. Mr. Malpica has the option to expand in the near future by renting adjoining rooms for additional office space and storage use. He plans to make the stations, which have no affiliation with a store, network or newspaper, the start of his own radio network.

FLOOR PLAN.

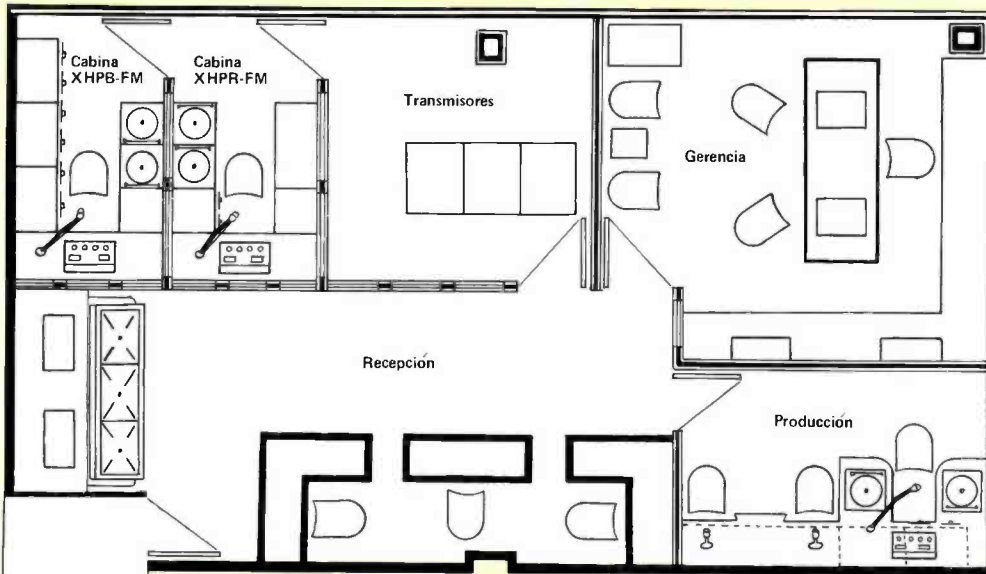



LONDON WEEKEND TELEVISION

BRIAN POVER, Controller of Engineering

The programmes for the Independent Television Network in Britain are provided by fifteen Independent Television Companies, of which London Weekend Television Ltd. is one of the major five.

London Weekend Television provides material for transmission from 7 p.m. on Friday to midnight on Sunday, being the nominated programme contractor for the London region during this period. During the remaining part of the week the Company is active producing programmes for both its own weekend transmissions, and for distribution on the national Independent network.

London Weekend Television is one of the new franchised companies which started transmission in August 1968, operating on 405 line standards in black and white only. Initial transmissions were made with equipment inherited from a former contractor occupying premises in North London.

L.W.T. recently purchased five RCA TR70B video tape recorders as part of its new colour installation. In this article, Controller of Engineering, Brian Pover, describes the Company's technical philosophy and outlines some of the problems the Company has faced in establishing a 625 line colour service.

Prior to the start of transmission, the management of London Weekend Television decided that they would build a new Television Centre on the South Bank of the Thames in London, to be completed by late 1972, and that in the interim period, the Wembley Studio Centre would be converted to full colour operation, in accordance with the requirements of the Independent Television Authority.

The Company decided to set up their own team of planning and installation engineers to plan both the new and interim colour Centres to meet the high technical standards set by the Independent Television Authority code of technical practice and provide flexible production facilities for their programme colleagues.

The first problem set for these engineers was that of converting an existing monochrome television centre to colour operation in the relatively short time scale of ten months, without diminishing the production capacity available to the Programme Division for maintaining the existing black and white service. As newcomers to Independent Television, London Weekend had the additional problem caused by potentially long delivery times for new equipment, without a previously established place in the delivery queues. Fortunately, the electronics industry responded to the challenge, and provided London Weekend with the necessary equipment for them to meet the target date of November 15th, 1969, for the start of colour transmissions.

The conversion of our technical facilities was based on a 'Master Plan for Technical Development' which embraced not only the task of conversion, but the planning and development of the entirely new complex for the Television Centre on the South Bank.

In outline, the task set for the engineers was that of planning the conversion to produce a technical complex which included four large colour television studios, a network presentation suite, colour outside broadcasting units, and all necessary supporting services, such as colour V.T.R. and telecine facilities.

It is a prime requirement of the programme companies' franchise agreement that the technical installations for both monochrome and colour transmissions should meet the very high standards laid down in the Independent Television Authority's code of practice. London Weekend Television decided that they would incorporate this requirement into their planning philosophy and in so doing avoided over-complicated systems. The engineers produced a number of system designs which were interpretations of the facility requirements of their programme colleagues. These sys-

tems were analysed and simplified to produce an arrangement containing the minimum number of active elements in signal paths. This method of analysing the problem resulted in an economic, yet flexible arrangement with the minimum added distortion.

Although it was recognised that going to colour would be an expensive business, our engineers were constantly reminded that their technical solutions must be cost effective and entirely viable. In consequence of the requirements to meet a high standard of performance at an economic rate, each equipment purchase was based on the answer to three simple questions :—

1. Does it do what we want?
2. When can we have it?
3. How much would it cost?

The first of these questions we considered all-important, and it was decided that in order to determine whether or not a unit or system met the London Weekend Television requirement, we must first define, in both objective and subjective terms, the true nature of the Company's need.

It may be interesting to note the method of acquiring equipment adopted by London Weekend Television. Our engineers met with their programme colleagues and discussed in general and detailed terms, the nature of the task to be performed, and set degrees of acceptability. From these assessments there grew a number of London Weekend Television specifications which sought to define what was best for London Weekend in meeting its end-objectives. These specifications were compared with those produced by manufacturers and wherever the manufacturer met the London Weekend Television requirement, a score of 100% was given. Relatively lower scores were given in accordance with our own assessment of the importance and degree of departure in each parameter. At this stage, visits were made to manufacturers to see equipment demonstrated, and to carry out objective measurements and confirm the claims made by manufacturers for their products. In cases where there seemed an obvious remedy for a shortcoming in a product, London Weekend Television requested the manufacturers to submit quotations for delivery and price of products modified to meet London Weekend's own requirements. The final selection of equipment was based on the nearness of the manufacturer's specification to the London Weekend Television requirement, the delivery time scale, and the final negotiated price. At no time was an equipment purchase made of a product which was inferior to the Independent Tele-

vision Authority and London Weekend Television performance requirement.

The L.W.T. team of planning and installation engineers was recruited from a variety of sources so that their collective experience covered every aspect of broadcasting, ranging from detailed design, development and installation to the full range of operational techniques. By this means, the engineers were able to plan a television complex with a balanced view of both technical aspects and user requirements.

At this point it may be appropriate to give a description of the London Weekend Television interim studio television centre based at Wembley. The Centre comprises four colour television studios, a large orchestral sound studio, a master control and presentation suite, a central tele-cine area containing seven colour telecines, four colour caption scanners and five opacity and transparent scanners. The scale of activity is indicated by the fact that L.W.T. uses 22 colour cameras. In addition there is a video tape recording suite containing five colour capable TR70B machines and one slow video disc machine. Other supporting services are provided from a central apparatus room and the L.W.T. outside broadcast, radio link and film units.

To overcome the technical difficulties imposed by the need to maintain standards when combining these

facilities during programme compilation, our engineers decided to centralize all active elements of the system in two geographically close areas. An interesting outcome of this decision was the fact that during the installation programme it was possible to operate one studio from apparatus in the central technical core whilst it's own equipment was being replaced with new colour facilities.

In the planning of the new installation it was decided that wherever possible automatic or semi-automatic processes would be incorporated in order to reduce the operational stress put upon production staff in making programmes. To simplify the task of connecting various facilities together electronic assignment was introduced, together with colour 'unipulse', so that combinations of sources could be married by simple switching actions.

In the case of the colour studios all the active system elements are located in a studio technical apparatus room. This room contains camera control units, colour encoders, vision matrices, unipulse decoders, test signal and measuring equipment, together with all associated monitoring facilities. One interesting innovation in our Wembley centre is the Technical Communication System which comprises an 'all to all' communications matrix capable of connecting any one of forty-eight sources to any one of forty-eight desti-

HEADQUARTERS for London Weekend Television.



nations. In this case we reversed the normal order of events and installed a communications system before installing the normal programme combination of sound facilities. This greatly assisted in checking out the installation before handing it over to the production staff.

The relatively short time scale available for planning and installation required the use of modern management techniques such as critical path analysis and project evaluation and review techniques. At one stage the activity network involved almost 2,000 simultaneous activities, and it became necessary to use a computer terminal for control of the installation programme. At the height of the programme, critical path read outs were obtained at almost daily intervals, so that equipment and human resources could be shifted in order to keep the installation programme on target.

In preparing for colour there were two overriding problems. The first was that of maintaining the full black and white production capability, and the second was the need to train the majority of our production and engineering staff in the new disciplines occasioned by working in colour. In management we recognised that only one or two of our operational staff had any practical experience of working in colour television, and that there was a need to organise an intensive training programme which would ensure that professional standards were achieved when we had to provide a public service in colour. The L.W.T. solution to this problem was to set up a senior management colour steering and training group, each with collective responsibility for training the staff in all divisions within the Company. This group was given all of the necessary financial and control authority to introduce a crash programme of training. The training was made difficult by the fact that we could not afford to interrupt either the programme-making activity or the technical installation. This ruled out the possibility of sending a large number of staff to organised courses at external training colleges, so we decided to solve the problem by using our own resources, reinforced with assistance from recognised subject authorities in industry. The steering committee classified the separate needs of the programme, production and engineering divisions in such a way that largely independent courses could be organised for each significant group. In the case of the engineering division, a syllabus was devised in collaboration with technical colleges and recognised experts in colour television, so that a total of thirty-three hours of lecture material could be prepared. These same experts and our own staff with experience gave lectures in front of television cameras in our own studios to staff who volunteered to be trained in their off-duty periods. All the lectures were video-tape recorded so that each lecture could be repeated until all of our staff had been able to attend for the full series of lectures.

Installation work for the first colour studio began



THE AUTHOR at one of five TR-70B video tape recorders.

at the end of January 1969 and by the time it was completed on April 1st 1969, most of the engineers had completed the theoretical training course and were ready for practical training. Immediately following the theoretical and practical training of technicians and engineers, practical facilities were made available to our programme and production colleagues so that we were able to provide fully trained staff in time to establish a three month stock pile of programmes in colour before the official colour starting date of November 15th, 1969. When we went on the air in colour last November, not only was the I.T.A. delighted with the technical quality of our material, so also were our fellow broadcasters.

By November we had installed £2½ million worth of colour equipment and every item had been subjected to the L.W.T. objective analysis before purchase.

Response from the broadcasting equipment industry on major items was excellent, and they went to very great lengths to meet our needs. I was particularly delighted with the cooperation we received from RCA who arranged to deliver five TR70B video tape recorders within our very tight installation time scale. Every machine met our specification with comparative ease in both objective and subjective terms. The first machine we received for an evaluation worked perfectly on arrival from the United States.

In addition to being supplied at the right price, it was delivered very much on time. It met the I.T.A. code of practice with sufficient margin to allow for the inevitable variation in performance which occurs in all equipment when in continual use for many hours. Just five weeks after accepting our order RCA delivered five machines.

All our engineers had been trained on other types of machines, so as part of the contract RCA trained sufficient engineers to enable us to get off the ground. In my opinion, the course provided by RCA at their Sunbury Centre was one of the best that I have come across, which deals with specific complicated items of equipment. Since we have had the TR70B's we have all been impressed by their performance, and with the comparative ease of operation. Although in operational practice, we set a limit of a third generation recording, some of our more skillful engineers have shown the TR70B to be capable of giving acceptable results on tenth generation recordings.

I am not aware of any other V.T.R. which would do that well.

Now that we have completed the conversion of our Wembley Studios to colour operation, and are actively engaged in the preparation of the new Centre, we have taken a retrospective look at the first part of our task, and remain convinced that apart from bringing us to our opening date on schedule, the carefully planned and objective approach has produced for us one of the best equipped colour centres in Europe.

Inevitably, in planning a centre of such complexity, our engineers found the need to incorporate facilities which were unobtainable as a proprietary manufactured item. In consequence, our engineering team designed and developed these additional items for installation, in our own premises. The largest of these

is a computerised lighting control system which can control up to 250 light sources and remember 100 combinations of selected lamps which may be set and remembered individually at thirty-two brightness levels. The range of items developed by our engineers is wide, and many of them have been so successful that we recently formed a subsidiary company—Dynamic Technology Ltd.—to manufacture and market units on a world-wide basis.

And what of the future? Although our present contract with the Independent Television Authority is scheduled to end in 1976, we are convinced that on the basis of having provided technical installations which met all the requirements made of them by I.T.A. coupled with an energetic and imaginative programme making division, we will be in a position to contend strongly for the renewal of contract.

Our new centre at Kings Reach on the Thames, in London, will represent a capital investment in the future of television to the extent of £7 million Sterling, and will, we believe, be one of the most comprehensive and technically sophisticated colour stations anywhere in Europe. Considerable pains have been taken to ensure that cost effective and high productivity technical innovations are contained in the new Centre. We believe that both now and in the future, London Weekend Television has made, and will continue to make, positive contribution to the development of the television industry.

IMPRESSED WITH PERFORMANCE . . . "some of our more skillful engineers have shown the TR-70B to be capable of giving acceptable results on tenth generation recording."



AN IDEA THAT GREW

WOOD-TV FINDS AV
AND TV PRODUCTIONS
BRING NEW BUSINESS

Making a time-and-motion study film in a shoe factory may not seem to be the thing for a TV station to do, but to WOOD-TV back in 1962 the idea of making movies seemed to be a logical extension of their broadcast services—and a way to bring greater returns on their multi-million investment.

Noting that businessmen were eager for coverage in the WOOD public service program that featured local industry, this enterprising station speculated that they would welcome the opportunity for similar films for general promotional use.

"Time-Life 8 Productions" was born with staff of two—wearing alternately the hats of manager, producer, salesman, writer, director, editor. Backed by the technical staff of the broadcast station they began operation. During the ensuing half dozen years, the fledgling company felt its way into sales-training films, sound-slide presentations, syndicated radio programs, TV commercials. Double use of television studio space and radio recording studios, together with skilled technical people in each department, made it possible to turn out high quality, professional productions.

As the original film company grew in size and scope, a new idea presented itself—the establishment of a complete Production Center—with production control facilities separate from broadcast control, and with sufficient equipment to consolidate film production with video tape facilities. After getting the nod from management, new highband video tape recorders, new sound recording and playback equipment, and new TV film systems were installed in 1969. These added

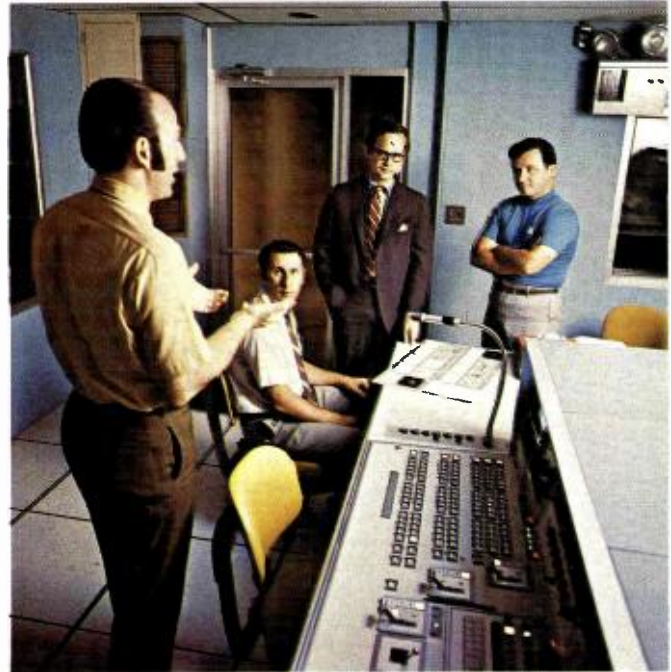

facilities not only served the expanding broadcast requirements of the station but provided a complete range of audio-visual and TV production services for the surrounding business community of Grand Rapids, Michigan. The addition of the new equipment has enabled the Center's sales staff to actively solicit a greatly increased number of prospective clients and over a period of one year has resulted in a 100 per cent increase in the number of TV commercials produced.

New Facilities Make The Production Center

"The new facilities have been installed for our growing broadcast requirements, and especially to provide a complete range of video tape and film production services for this expanding business," according to Engineering Manager for TV Production Facilities, Robert C. Smith.

Studios and Control

The studio and technical equipment area is constructed on one level, with the new production control complex being located opposite the on-air control complex. Computer flooring is used in this area for ease of installation and maintenance. Formerly, a single control room served both studios. Now Studio "A" and one control complex handle broadcasting, while Studio "B" and the other control handle the Production Center.

The new color production control features independent video control of the live color cameras, including two TK-42's. Special production effects are

supplied by a TS-51 vertical/interval video switcher with dual reentry and a special effects generator with chroma key insert. This switcher has sixteen composite/non-composite inputs for five live cameras, three film islands, and four television tape recorders, as well as Net, Remote, Studio "A" and Black.

A large viewing window located just in front of the new production control gives operating personnel an unobstructed view of production activity in Studio "B", the production studio for films and TV. To the immediate left of production control is a newly constructed announce booth—completely independent of the one serving Studio "A" and "on-air" needs. In this way the Production Center has complete and separate studio facilities—and production is never affected by on-air commitments.

Audio facilities in the new production control area consist of a 36-input dual-channel audio console with preview, switchable filters, isolated studio feedback and integrated intercom as well as reverberation. In addition, there are two cartridge recorder/reproducers and a 1/4-inch audio tape recorder/reproducer. A BQ-51 Turntable also feeds the console. There are also two PM-75 16mm magnetic recorder/reproducers which may be used for double system audio, rerecorded through the production control console. These same recorder/reproducers may also be used for double system audio and video playback in interlock of 16mm film to either the production center or air control.

Telecine Area

The TS-51 Switcher is tied into the new Telecine area



FROM STORYBOARD TO PRODUCTION, these photos show a typical commercial in preparation. The storyboard is reviewed with the agency. Talent is briefed in a rehearsal conference. And finally the project takes to the studio for production.



TELECINE area includes three TR-70 tape recorders which share both production and playback duties.

which is located just behind Studio "B". The Telecine area also features an air supply which is electro-statically filtered to further approach a "clean room" condition.

One of the unique features of WOOD-TV's new production center is a complete "in-house" compressed air system. The central compressed air system, providing the essential air pressure for the center's video recorders, is located in the basement of the station's main building. This isolated air supply system provides the production center with a lower ambient noise level in the Telecine area as well as compressed air for projector film gate cleaning, the carpentry and electronic shops, and the film processing center.

The Telecine area is constructed on a computer type floor which has been covered with a carpet containing metal filaments. The carpeting not only serves to "beautify" the area and contributes to the general cleanliness, but it also reduces noise. The metal filaments in the carpet prevent the occurrence of static discharge.

The Telecine area contains three complete 16mm TK-27 Color Film Chains, with three TP-7/TP-77 Slide Projectors, four TP-66 and two TP-6 Film Projectors, and three TR-70 Television Tape Recorders. The TR-70's are equipped with CAVEC and CDOC to give finest color and automatic control of picture quality. These sophisticated TR-70's are used for creative TV productions as well as "air" playback of program material.

Range of Services

The years have brought many changes in the Time-Life Productions organization in expansion of personnel and diversification of projects. Movies and filmstrips have been produced for business, industry, education. As an adjunct film processing in color and monochrome for 16mm movies and 35mm slides is also offered. Audio taping and dubbing, art and editorial services, constitute the complete range of services.

Time-Life film crews are well known in western Michigan and clients are as varied as the projects. Included are films on time-and-motion study for Hush Puppies shoe factory, diagnostic procedures for the Upjohn Company, surgical operations for the Ferguson Clinic, contributions of Michigan highways to the state's economy—for the County Road Association, and an Educational Project Documentation of innovative teaching methods for the Detroit School District.

For television stations, Time-Life 8 Productions has for several years supplied a series of slides made from original art outlines on each state, color coded, with yellow outlines on blue stock. A second series of three sets has just recently been issued covering all the provinces of Canada, the countries of Central and South America—each set having its own color code.

Getting Into TV Production

According to Operations Manager, Stan Barnes, the Center is presently engaged in production of television commercials for many accounts. Clients range from such national ones as Cooper Tires, Amway Homecare Products, Lear-Siegler, Inc., and the Grand Rapids'-based American Seating Co., the world's largest maker of public seating, to regional clients as The Kroger Co., and Consumers Power Co. Local clients include



the city's two largest banks (Old Kent and Union), several department stores (Wurzburg's, Herpolsheimer's) and several high-volume auto dealerships (Coe Pontiac, Duthler Ford City).

The bulk of the TV commercials are done through local advertising agencies, very few result from direct dealings with the advertiser. Nearly all commercials are for local clients, since most national accounts are nested in the big cities. Local commercials are all done on tape while those for multi-markets are usually done on film, since it affords better mobility for distribution. However, even those distributed via film are frequently produced on tape and then converted to film.

Approximately 50 television commercials are produced monthly. Half of these are generated by normal contacts of TV time salesmen, the remainder represent the efforts of Production Center salesmen.

"Our business outlook for 1970-71 is extremely good" reports Mr. Barnes, "based on the first few months of operation since the Center was established."

Cultivating A Growing Business

The Production Center has a separate staff headed by a Managing Director and under him are: Sales Manager and Operations Manager. Remainder of staff includes two writer/producers, two production photographers, a sound engineer and a secretary/production aide. Technical personnel are shared with the on-air operation.

This staff is engaged solely in film and video productions—except photographers who have some routine station program assignments also. Production of programs are handled by another staff. This keeps the Production Center a completely independent operation—accountable for its own profit and loss statement.

Naturally, film productions constitute the major portion of the Center's business at the present time, because that's where the idea sprouted. However, 65 to 70 per cent of the commercials are produced on video tape, so in one respect—there's a trend away from film. On balance the outlook is good in both areas. The only problem is that of every station in typical midtown America.

"WOOD-TV Production Center has the problem of a medium size city," according to Mr. Jack Markward, Managing Director. "We're away from the large centers where most national buying originates and where the larger industries are located. On the other hand we can offer attractive rates coupled with highly creative talent and finest facilities. The big problem is to unearth leads and make contacts. Once we can show what we can do, it's not so much of a problem.

"The Production Center was an evolutionary process—a natural offshoot of our bread-and-butter broadcast business. While not yet a smashing success, it is paying its way.

"In 1969 we conceived the idea of a Production Center and spent heavily for new equipment to implement our idea. It's a thrust geared strictly to be able to create productions for clients without interfering with on-air programming. Now we can offer a production studio with full facilities that are not tied up by the station's broadcasting commitments. In addition, we have two mobile units—unusual for our area—one for video recording and one with live cameras, both can handle color.

"This is a relatively new operation . . . we're tilling new ground—and we're prepared to learn and to reap—as we grow."



SYNDICATED TREEHOUSE CLUB. The facilities of Time-Life Production Center are being used by Sound Associates of Grand Rapids to produce a new children's religious program, **THE TREEHOUSE CLUB.** Hosted by Erl, the Purple Squirrel, the half-hour TV show is directed towards children ages 5 through 9. Included in the program is a treehouse set with nine children, Erl, Friend (owner of the Treehouse, who is heard but not seen) some attractive and very funny hand puppets, a singing session in which the kids at home are urged to join, and a Bible story featuring artwork depicting the characters mentioned.

Sponsored by Child Evangelism Fellowship of Grand Rapids, a world-wide ministry to children, the program teaches simple Bible truths on a child's level, as an antidote to the overabundance of violence, crime, sex and materialism to which children of today are exposed.

The first 13-week video tape series will be ready for distribution by October 1, 1970, and is available free of charge through Sound Associates. Nationwide syndication of 72 television stations is planned by January 1, 1972. Glossies of the show, as well as a video tape sample, are available for interested TV stations.

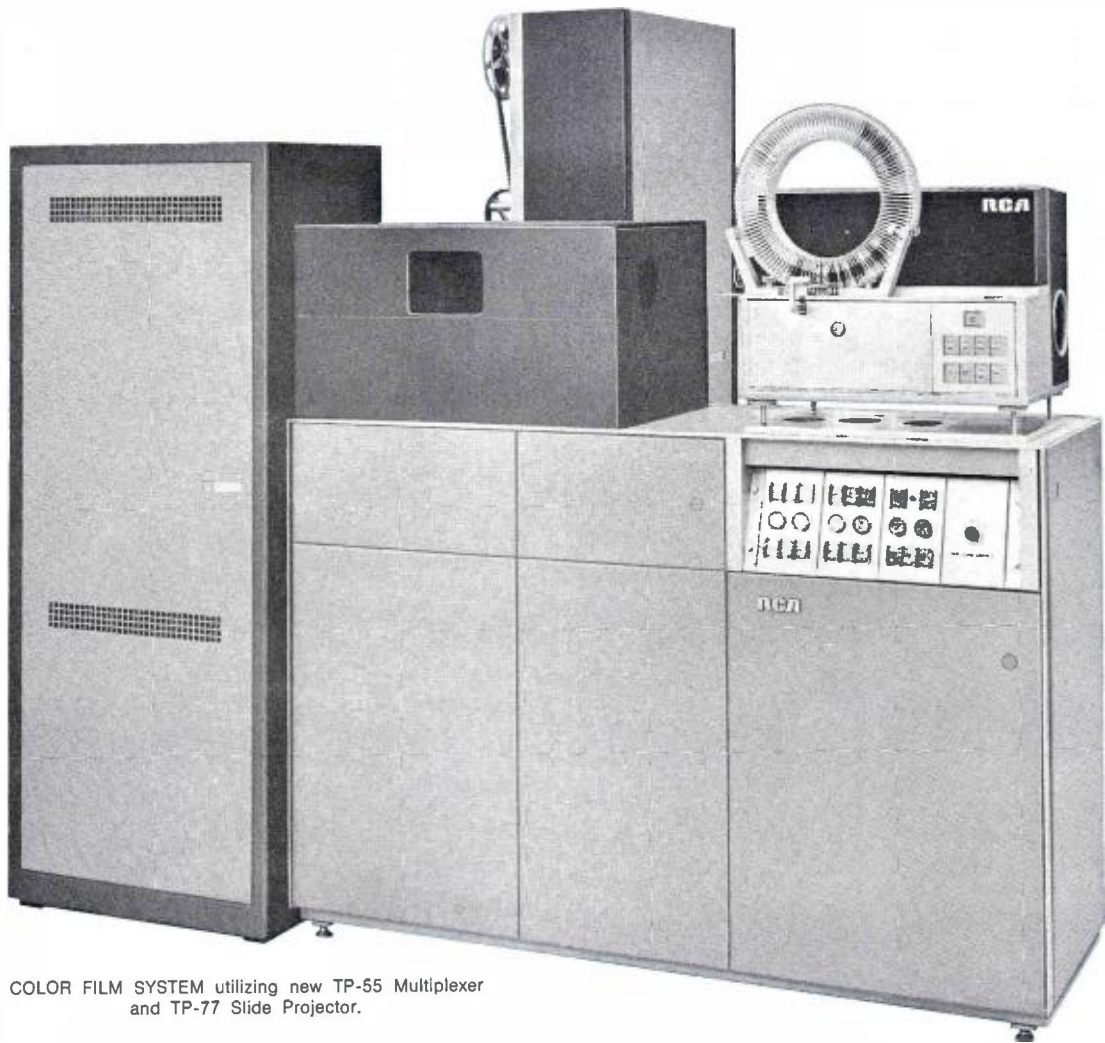

COLOR FILM SYSTEM utilizing new TP-55 Multiplexer and TP-77 Slide Projector.

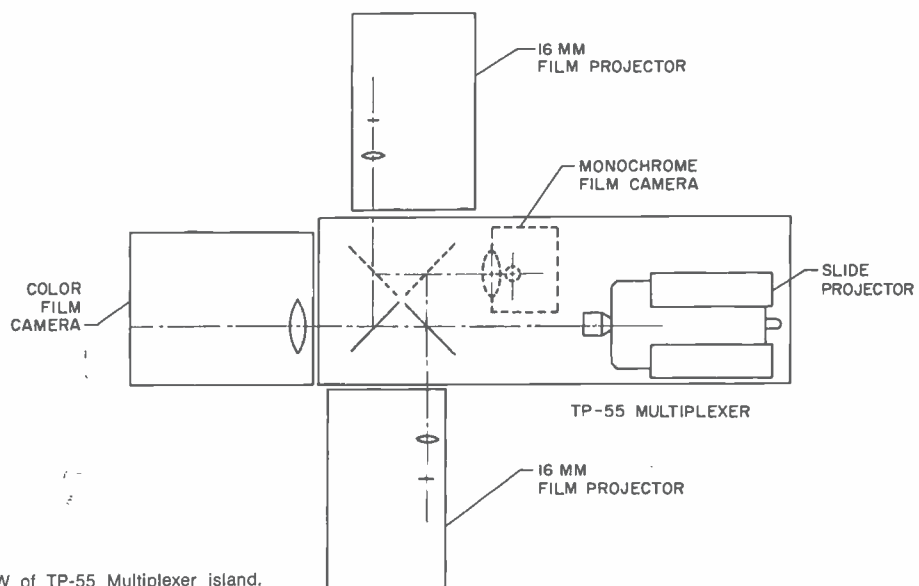

PLAN VIEW of TP-55 Multiplexer island.

NEW SOLID STATE MULTIPLEXER FOR COLOR TV FILM SYSTEMS

A. E. JACKSON and C. MANGIARACINA

Optical multiplexing for television film programming has a long history, establishing both the need and the usefulness of the RCA equipment. The new TP-55 Multiplexer incorporates many improvements that speed setup, make operation more reliable, and the effect more professional.

Some of the new features include:

1. Wipe-type optical transition. No "dark" interval during switching to disturb camera circuits.
2. Provision for a central distribution area of island control wiring and island power wiring.
3. Rigid single-pedestal construction, assuring optical alignment.
4. All solid state control circuitry for utmost reliability.

The TP-55 (like its predecessor, the TP-15) is based on a cluster of four moveable mirrors, around which three projectors and two cameras are normally grouped. The mirrors may be programmed to move into or out of the optical paths in a manner that they will direct the projection beams from any one of the projectors into the optical input of either of the cameras. An optical image is formed on a field (or condenser lens) at this point. This image is then relayed by internal camera optics to the actual point of scan within the camera. Either of the two remaining projectors may be "optically switched" to the remaining camera by proper programming of the remaining mirrors. The TP-55 Multiplexer is compatible with all the previous RCA cameras and projectors by using the proper field lenses, camera lenses and projection lenses.

Single Pedestal Construction

In the plan view of a TP-55 Multiplexer island, the four moving mirrors are seen in their proper relation to the color film camera field condenser lens input, the monochrome film camera field condenser lens input, and the various projectors. Two film projectors are used on the side input ports and a slide projector on the direct input port. A single rigid pedestal is used to support both the mirror assemblies and the slide projector. By using an auxiliary stationary mirror, the optical axis to the second (monochrome) camera is changed from a horizontal to a vertical direction, which permits mounting this camera within the pedestal enclosure.

This overall system is shown in the photo at left with one of the newer slide projectors in place (TP-77). The mirror assemblies are housed under a dust

protective cover. A sliding panel provides access for cleaning or servicing. The second (monochrome) camera is mounted behind the hinged door in the center section.

Centralized Wiring

Control circuitry is behind doors under the control panels. These panels may be relocated if desired to an alternate location on the other side of the pedestal, directly opposite that shown.

Figure 3 shows the junction areas that serve as the primary tie points for control and power wiring for the entire film island. The control junction area is located on the back of a hinged door so that it will swing out of the way when access is desired to this

JUNCTION AREAS that serve as primary tie points for control and power wiring.

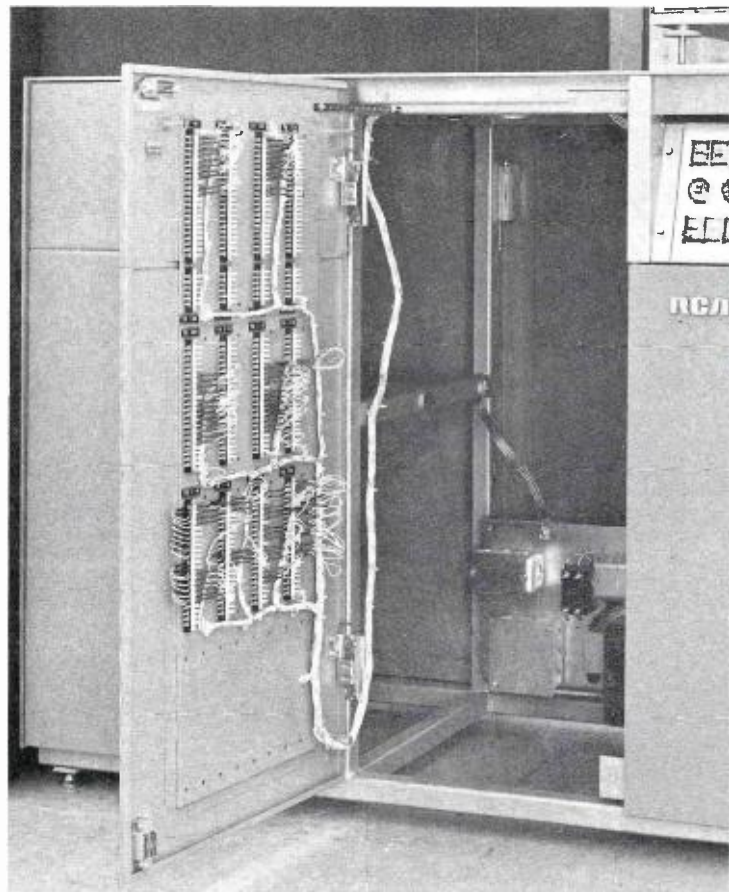

area of the pedestal (2nd camera location). The power junction area is located on the opposite side of this compartment.

Fast Vertical Mirrors

The four mirrors are mounted with their optical center nominally 48 inches from the floor. These mirrors are first surface to avoid ghost reflections. They are moved vertically in the plane of their reflecting surface so that they do not cause any image movement during the transition.

The mechanism (Fig. 4) for vertical motion can be moved fast and also conveniently stop the relatively large mass represented by the mirror assembly. Braking is effective enough to stop within 20 degrees angular displacement of the output shaft of the drive motors. The result is a complete optical transition in 200 milliseconds.

An innovation in this equipment is the use of light actuated switches to sense mirror position. These switches consist of a photoconductive cell, a light source and a shutter blade. The lamps are operated at a voltage that permits an anticipated life in excess of 10 years.

Solid-State Modules

All solid state control circuitry is used. This circuitry is packaged on plug-in modules that are located in a frame mounted in the pedestal. The basic circuit is contained on three modules: mirror power, logic, and tally.

MOVING MIRRORS perform complete optical transition in 200 milliseconds.

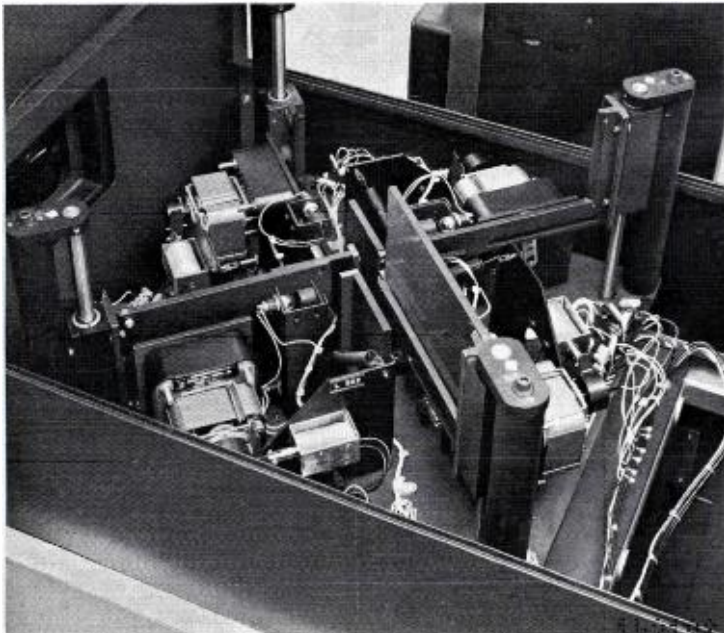

A 24V DC Power Supply is provided from which control and tally power are obtained. All controls are initiated by a +24V pulse and all tallies operate on +24V DC.

The remaining space in the frame may be used for mounting optional modules such as the Light Control switcher.

Logic Module

All circuits required to provide the logic for switching and tally of the multiplexer are contained in the Logic Module. Twenty-five digital integrated circuits operating at a nominal 0 and +5 volt logic level are used in this module.

Mirror changes are initiated by a +24 volt control pulse received either from a manually operated "show" switch or from an automation system. The important feature is that once a command is accepted by this logic, it will be retained and all other commands will be rejected, until the conditions requested in the initial command are fulfilled. Another important feature of this logic is the programming of mirror changes when two or more mirrors are involved so that the "On-Air" camera will always be "seeing" a projector source.

The output of the logic module provides logic level signals for operation of mirror change motors and logic level signals for mode indicating tallies.

Mirror Power Module

The mirror power module is typical of the type of plug-in module used for the control circuitry in the TP-55 Multiplexer. This module contains the power switching circuits for the mirror motors. All solid state components are used in this module.

Tally Module

This module receives signals generated in the logic module for mode indicating tallies. Since the common film studio control and tally voltage is +24V DC, the logic module contains the necessary amplifiers to raise the tally signals produced in the logic module from the 5 volt logic level to the +24V DC system level. All solid state components are used in the Tally Module, with a maximum output capability of 4 amps for each tally function.

Conclusion

The main advantages of the new TP-55 Multiplexer stem from use of solid state circuitry and a single pedestal structure that combines maximum rigidity with maximum accessibility. Fast vertical mirror movement gives wipe-type optical transition between slides—without "dark" interval. Four projectors and two cameras may be accommodated. It provides the nucleus of the finest film system for both color and monochrome television operation.

IMPROVING RELIABILITY OF TV MICROWAVE SYSTEMS



E. L. FARMER and R. REYNOLDS

1. RACK OR PORTABLE mounting is featured in RCA Microwave Systems . . . TVM-6 for 6 GHz operations and TVM-13 for 13 GHz operation.

Microwave systems are important links in today's broadcast operations. They are effectively used to relay TV pickups from a stadium downtown, or any other remote point, to the station. Frequently they are used to link studio with transmitter. They represent a small investment in some TV plants, a large one in others. However, when they fail, communications stop—no matter how sophisticated and reliable other parts of the operation may be.

Since studio-transmitter links are vital to continuous on air broadcasting it is hazardous to operate without any provision for fault reporting or emergency situations. Many stations are finding that standby equipment vastly improves the performance of even the finest systems. Further, the addition of automatic fault sensing and standby switching can help change costly emergencies into routine maintenance procedures. And these newer devices may be added to older systems.

With remote control of UHF transmitters a fact, the reliability of the microwave link assumes more importance than ever. The newest RCA microwave systems feature solid state modular design, simplifying operation and maintenance, improving performance. They transmit high quality color over single and multi-hops for STL or intercity nets.

Basic TV Microwave System

Microwave systems serve to transport intelligence from one point to another. In this case, the intelligence is the composite video signal, usually with its accompanying program sound. The basic system consists of a transmitter at the originating point and a receiver at the point of destination, each with an appropriate antenna, and capable of relaying the signal with a minimum of added noise and distortion.

Achieving Quality and Reliability

Quality of performance and the reliability of the microwave system depend upon several factors, including: The design of the basic transmitting and receiving equipment; design of the antenna, and the built-in protection against excessive signal attenuation over the microwave path; redundancy provided for protection against equipment failures; and the reliability of the primary power source.

RCA Type TVM-6A (5.925-7.425 GHz) and TVM-13A (10.550-13.250 GHz) TV Relay Equipment utilize the latest solid state design techniques and components to provide the ultimate in performance and equipment reliability. It is equipped with extensive built-in test and monitoring features which facilitate performance checks with the equipment in service, and convenient replacement of defective modules.

The excellent reliability inherent in the design of the equipment may be further improved by selection of equipment items offered as accessories for particular applications.

Reliability Enhancement

To supplement good preventive maintenance practices which include periodic checking of equipment performance, the most obvious method of improving reliability is through the use of "fault sensing" equipment. This automatically detects an off-normal condition and produces an alarm signal so that corrective measures can be taken before a complete outage occurs.

Where still greater reliability is required, complete standby transmitting and receiving equipment may be employed. Switching from main to standby equipment may be manual or automatic, and with or without the automatic fault sensing feature. Combining fault sensing and automatic switchover, however, increases system reliability far beyond that to be expected by use of manual switching.

Automatic switching as applied to receivers may be further expanded by use of space diversity, where the receivers are fed by separate antenna systems. This arrangement has the additional advantage of increasing the propagational reliability of a transmission path by a factor of ten or more. The same reliability advantage may be realized from frequency diversity—when an additional frequency is available.

Addition of the TVM Alarm System to those accessories described above provides for automatically sensing and transmitting to a supervisory point up to eight failures (or marginal operating conditions) from as many remote locations. Alarm signals are normally transmitted by means of a subcarrier on the microwave system but may be sent over a leased telephone wire. Faults are not limited to equipment. They can include tower light failure, power failure, illegal entry and others.

Typical systems showing methods of improving microwave reliability and the accessory equipment required to implement them are discussed in the following.

TVM Fault Sensing System

Figure 2 illustrates use of RCA fault sensing accessories at the transmitter and receiver to monitor equipment operation and produce alarm signals when monitored conditions fall below predetermined levels. This would be suitable for a simple STL system where control signals are not carried. Here, the reliability of the non-standby system is enhanced by devices such as the Video Presence Indicator and the Low Power/Low Signal Indicator.

These units are slide-in modules which may be installed in the transmitter control, receiver control or accessory control nests, and provide contacts for the actuation of external devices. As previously mentioned, with the TVM Alarm System, up to eight off-normal conditions from eight remote unattended locations can be reported to a central monitoring point. Accessories are fully compatible with earlier TVM microwave equipments.

Standby With Manual Switching

Standby in its most elemental form is illustrated in Fig. 3. In this system, the two transmitter outputs are routed to the same antenna by means of a three-port ferrite circulator and RF switches, which are an integral part of the transmitter. Switching from one transmitter to the other is accomplished by placing the active transmitter in the operate condition, thus operating the RF switch to the ON position, and placing the standby transmitter in STANDBY, operating the RF switch to the OFF position. RF energy from only one transmitter enters the ferrite circulator and is transmitted to the receiving location.

Of course this does not provide for automatic fault sensing or automatic transmitter switching. Therefore, it is suitable only for an attended location such as a television studio. An off-air video monitor line can be brought from each transmitter to a picture monitor in the control room for observing the quality of the transmitted signal, and operate-standby switches located accessible to the operator.

At the receiving location, the two receivers are connected to a common antenna through a 3 dB directional coupler, which serves as a power divider, feeding equal RF signals to each receiver. The only switching required here is the selection of the desired receiver output. Since both receivers are delivering video at all times, both active and standby receivers may be monitored.

Active and standby transmitters are fed video information from a common source by use of a distribution amplifier. The common audio source is fed to the sound diplexing unit in each transmitter by means

of a resistive splitting pad or other device.

Considerable additional protection against propagational fading can be provided by using a separate antenna system for each receiver in a space diversity arrangement. The directional coupler is not used, and the receiving antennas are physically separated by a distance of approximately 40 feet, depending upon path length and frequency.

Fully Automatic Standby System

Figure 4 illustrates a system with standby transmitters and space diversity receivers, each with fully automatic switching of equipment and audio. Also included is the TVM Alarm System to provide sensing and reporting of equipment faults. This is typical of a system that might be used for remote control of a transmitter.

Although only one sound channel is shown, the system may be expanded to include up to three sound channels in each transmitter.

Incorporating two TVM-6A or TVM-13A transmitters each with its own sound channel and off-air audio and video monitoring, the system affords protection against low RF power output, modulation failure, sound subcarrier failure, power failure to any one of the transmitters, and failure of the switchover equipment itself.

Video is taken through the accessory nest to derive outputs to feed the two transmitter control units. In each unit video passes through an input amplifier with the sound subcarrier filter, then picks up the sound subcarrier and is fed to the transmitter RF chassis.

2. AUTOMATIC FAULT SENSING block diagram for TVM-6/13 systems.

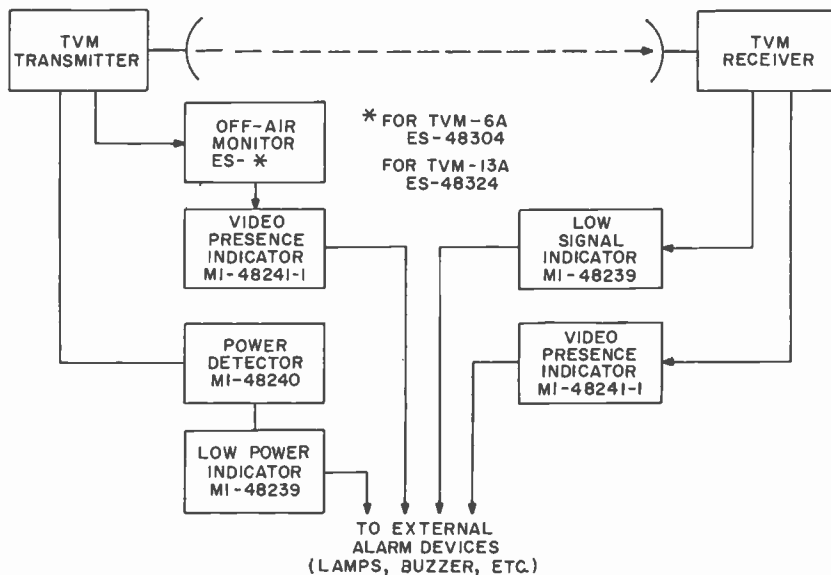

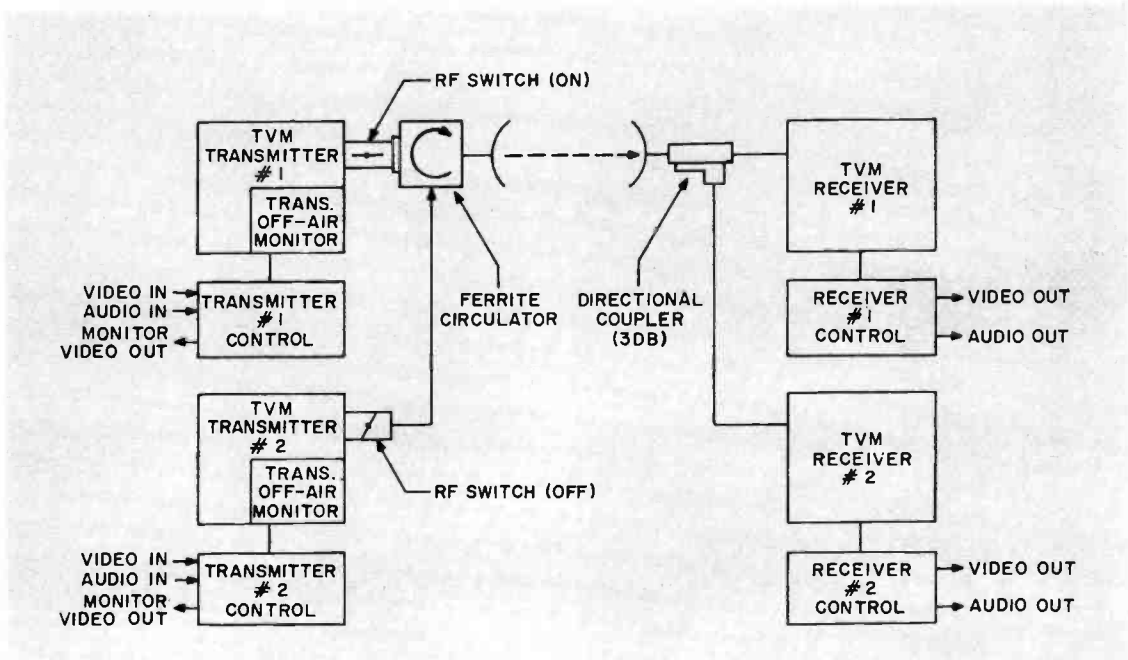

3. MANUAL STANDBY SYSTEM block diagram for TVM-6/13 systems.

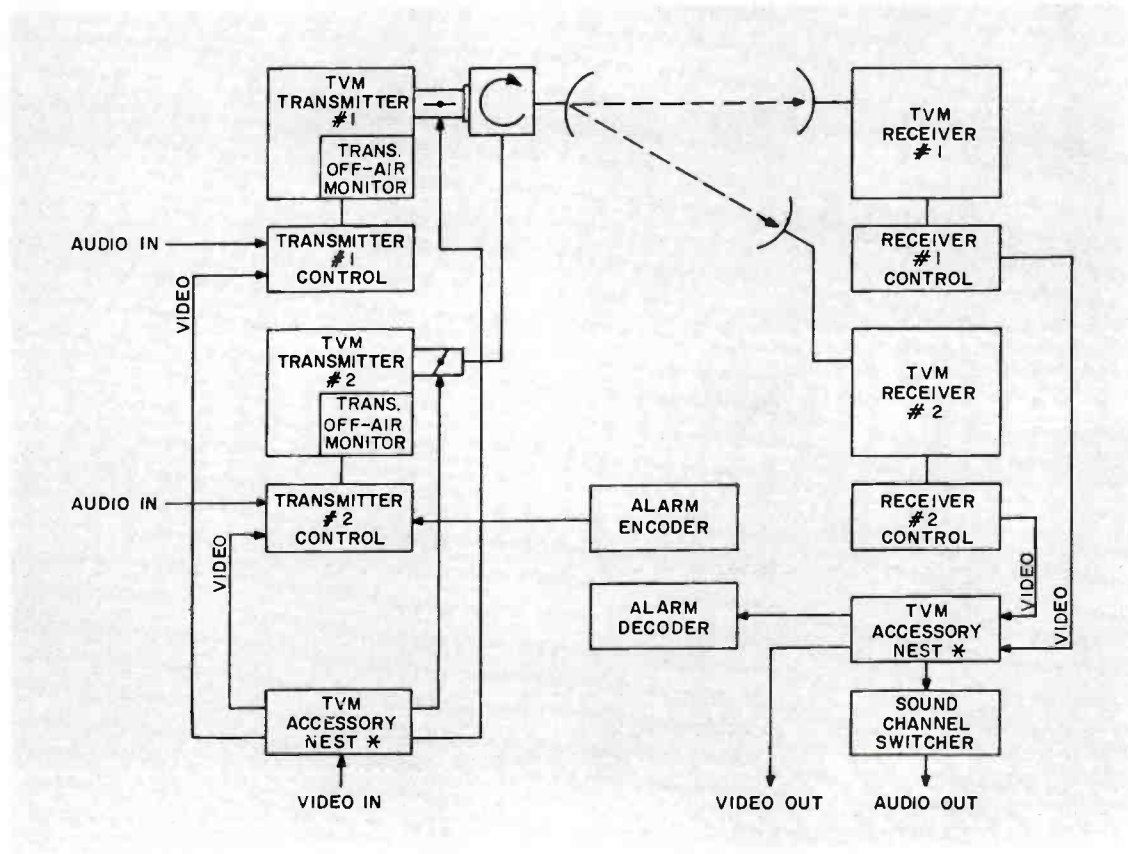

4. AUTOMATIC STANDBY SYSTEM block diagram for TVM-6/13 systems.



ACCESSORY NEST, consisting of slide-in modules in rack mounting frame.

Reliability Accessories



VIDEO PRESENCE INDICATOR



TRANSMITTER STANDBY AND DIVERSITY SWITCHER



LOW POWER/LOW SIGNAL INDICATOR

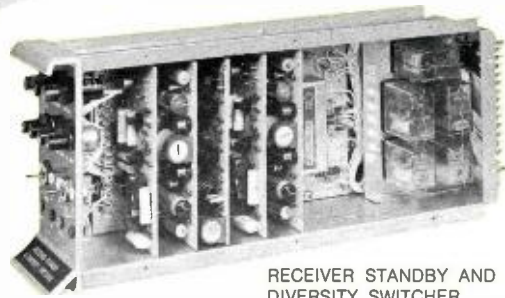

RECEIVER STANDBY AND DIVERSITY SWITCHER

AUTOMATIC ALARM ENCODER

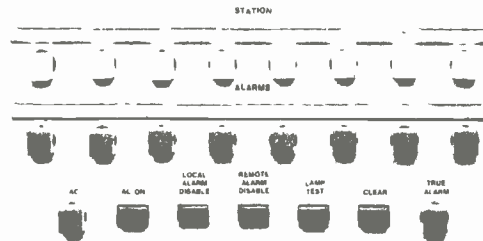
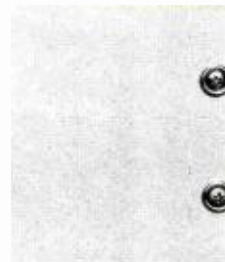
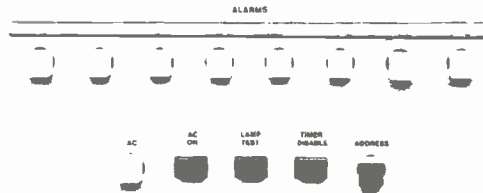
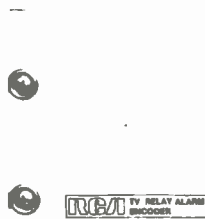

AUTOMATIC ALARM DECODER

The off-air monitor line from each RF chassis is brought to the accessory nest where sensing connections to the transmitter standby switcher are bridged, then to the monitor input of its own transmitter control unit. In each control unit the monitor line feeds the sound demodulator, then goes to the output amplifier, which includes a subcarrier filter. Off-air video and audio are available at each transmitter for monitoring.

Sensing of the sound carrier is provided by a DC output derived from the sound demodulator and fed to the transmitter standby switcher. In multiple sound channel systems only one sound channel in each transmitter is sensed for switch-over purposes.

When the equipment is first turned on, the switcher places on-air the transmitter that is first with RF power, subcarrier and video. This transmitter stays on the air until it experiences a drop in level of any of these signals. Switches in the two transmitter RF chassis are wired so that when one transmitter is ON the other must be OFF. A waveguide switch may be used in place of the ferrite circulator to feed RF to the antenna.

Transmitter No. 1 may be regarded as the *main* transmitter (and No. 2 as *standby*) because a power failure to the switching equipment will place No. 1 on the air. As long as all units have power and are operating, neither transmitter is normally favored although it is possible to offset the balance control in the switcher to favor either during operation.

The transmitter switcher may be operated manually by test switches on the front panel, or remotely by an override available on the rear of the accessory nest.

At the receiving end are two TVM-6A or TVM-13A receivers with their own sound demodulators. Video output is selected by the standby diversity switcher. The accompanying audio signal is selected by the sound channel switcher. Power failure to the switching equipment will place receiver No. 1 in use.

Video output of each receiver is taken through its own control unit where sound subcarrier is picked off and video output levels are set. Each video signal is then fed to the accessory nest where it is sensed by the switcher, and both the selected and idle signals are forwarded to the output of the accessory nest. Idle output is forwarded for test and monitoring. An optional tee patch module will provide two 75-ohm outputs from the selected video, but may be omitted if only one output is required.

When the equipment is first turned on, the switching equipment will select the receiver that is first with complete output, e.g., receiver AGC indicates substantial RF input, subcarrier level and video output nor-

mal. The selected receiver will stay on until a drop in level occurs in a sensed component. No switching occurs when video levels drop simultaneously on a signal fade or subcarrier failure. Switching equipment will not operate if other receiver is also in a fault condition.

The No. 1 receiver may be regarded as the *main* receiver since a power failure to the switching equipment will cause selection of this receiver. The switching unit contains a balance control, which, in operation, will permit either receiver to be favored. The receiver in use may be switched out manually by switcher front panel test switches. These controls simulate various failures for test purposes, but do not interfere with the signal in use. A remote override switching connection is available at the rear of the accessory nest.

If the system is used in a frequency diversity arrangement with a common antenna at each end, transmitter switching is not required since both transmitters are on the air at the same time and on different frequencies.

System capability may be reduced, if desired, to sense a smaller number of operating parameters at a corresponding reduction in cost. Any combination of features is available to meet specific requirements.

Typical Microwave Installations

Typical of RCA TV microwave systems are the installations of KSOO-TV, South Dakota (see Fig. 5), KMST, California, and WDAY-TV, North Dakota. Services include network and station feeds and STL. All use TVM equipments. The four-hop, 150-mile WDAY-TV system, stretching from Alexandria, Minnesota to Fargo, North Dakota, is a TVM-6A that recently replaced the original TVM-1A equipment.

Compatibility with Early TVM Equipments

The TVM-6A and TVM-13A equipments make it possible for the almost 1500 owners of early TVM microwave systems (still in use) to update their plant facilities, or to add modern, more reliable solid-state equipment to gain backup protection.

Even earliest TVM-1 equipments, introduced in 1954, are readily integrated into standby systems with the TVM-6A using existing antenna and waveguide. When the TVM-1 is directly replaced with the TVM-6A, using the same antenna system over the same path, an added 6.0 dB in fade margin and video signal-to-noise ratio is realized.

Most Complete Monitoring Facilities

The TVM-6A/13A equipments retain all the desirable

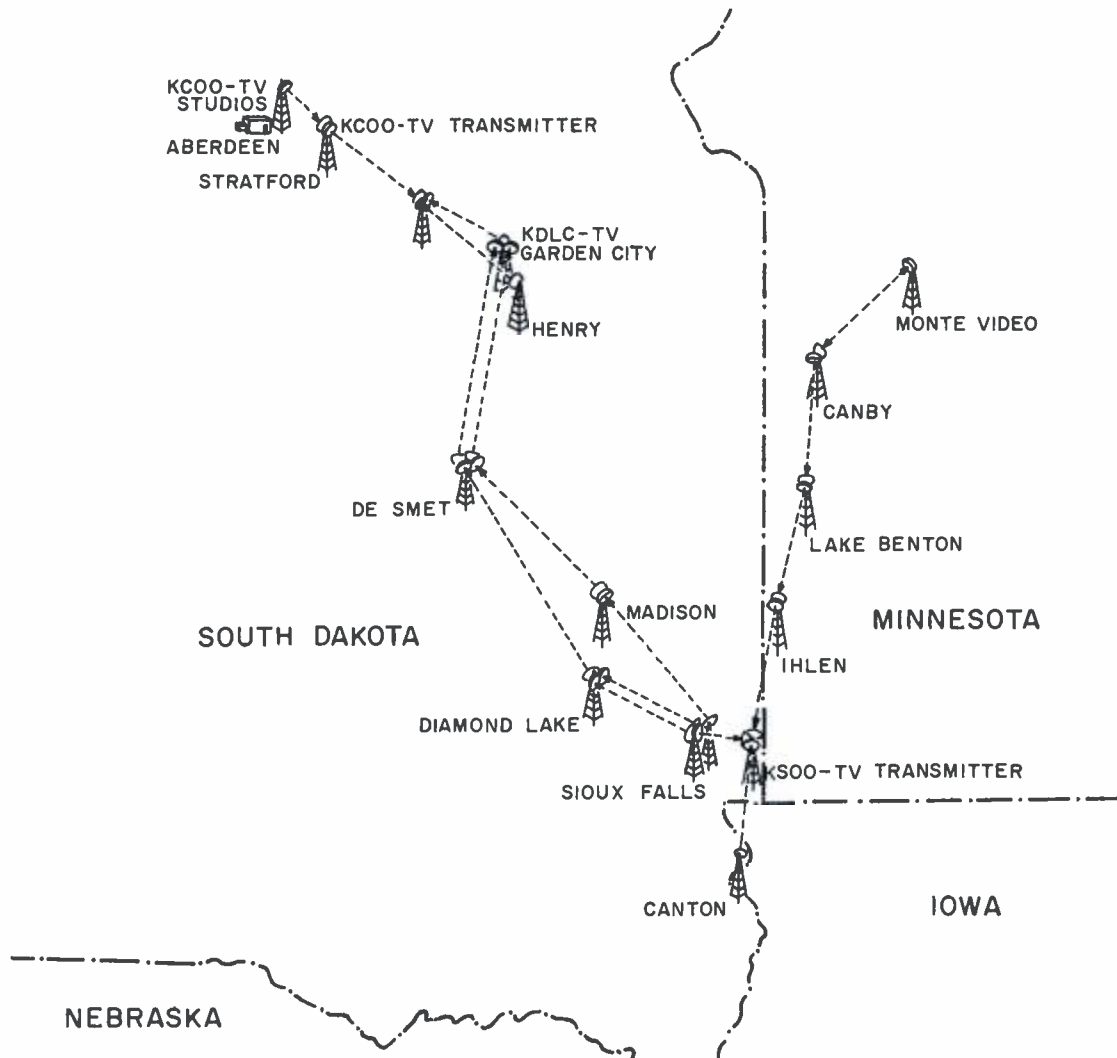

5. MICROWAVE NETWORK of KSOO-TV, Sioux Falls, S. D.

advantages of the TVM-1 such as the directly calibrated wavemeter, high quality off-air monitor, color-coded multiple circuit metering and built-in test signals.

It has further expanded upon these features. Built-in facilities now completely eliminate the usual, complex array of frequency meters, modulation meters, audio level meters, video test signal generators, waveform monitors, video line equalizers and other equipment, to make it the most complete integral monitoring and testing microwave system in the industry.

Conclusion

Most microwave applications require systems with exceptional performance and reliability. Achieving these qualities in a microwave link relies heavily on both equipment and system design, with equipment playing a foundation role.

The RCA TVM-6A and TVM-13A TV Relay Systems meet the rigid requirements for single hop or multi-hop fixed stations and have the versatility for portable and remote pickup operation in studio-to-transmitter links and intercity networks. They are designed to provide the performance and reliability required for the transmission of high quality color and monochrome signals and transmitter control signals.

The design of almost every TV microwave system is an individual case, calling for an endless variety of equipment configurations. This need for equipment versatility is met by the basic system packages presented in this article. They may be used in almost any combination with the vast array of available accessories to satisfy any system requirement, and to provide the user with a means to expand his system to obtain the fine performance of which the equipment is capable.

Products in the News

TK-44A S/N versus Light Level

Sensitivity and S/N for the TK-44A Camera is specified as follows:

When the camera is viewing a 60% reflectance Munsell under 125 footcandles incident light of 3200K and the iris aperture is set at $f/4$, the output from the chain shall be 0.7V white and the signal-to-noise ratio shall be not less than 48 dB.

The above conditions to be met with an applied gamma correction of 0.5, no aperture correction, chroma off, a typical set of PbO tubes and a bandwidth of 4.2 MHz.

The full significance of this excellent specification may not, at first glance, be apparent. The nomograph shown is given as an aid to easily interpret the specification in practical terms, showing the effect on S/N—as light level and/or lens aperture is varied while maintaining full video level.

The line shown represents "normal" lighting conditions as they have been specified. As the light level changes during operation, the iris or aperture is adjusted to maintain proper video level. Under these conditions, the line will rotate on the X axis shown on the nomograph. S/N of 48 dB will be maintained if a reduction of light level is compensated for by opening the iris. If the iris is opened to its maximum aperture, full video level can be maintained down to approximately 30 footcandles. There will be no reduction in S/N.

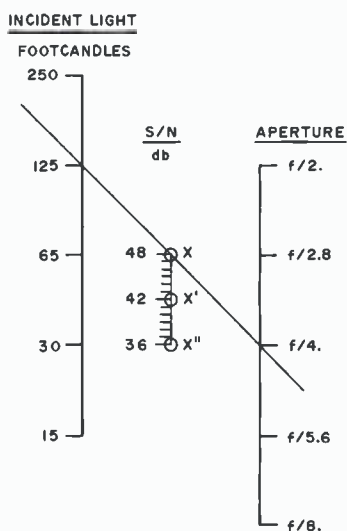

It can be clearly seen from the nomograph, that much lower light levels can be used with good results. For example, if video gain is increased so that 65 footcandles of incident light produces full video level with an iris setting of $f/4$, it can be seen that the S/N will drop to 42 dB. As the iris is adjusted to compensate for changing light levels, the line will now rotate on the X' axis. This represents a noise figure at 65fc which equals or exceeds the maximum S/N achievable with many other broadcast color cameras.

From this, it is quite apparent that the TK-44A can be operated satisfactorily at light levels commonly used for monochrome operation. The saving which can be realized in expenditures for lighting fixtures and air conditioning load is obvious.

S/N performance under extremely low light levels which might be encountered in the telecasting of night-time sporting events is shown by the nomograph to be surprisingly good. Note that a light level of only 15 footcandles using an aperture of $f/2$ produces a S/N of 42 dB. Closing the aperture one f /stop and increasing preamp gain reduces the S/N to 36 dB (rotating on the X'' axis) a figure which is still quite acceptable for operation under adverse lighting conditions, where other cameras could not even begin to produce acceptable pictures.

Precise Frequency Control System, TFC-1B

It is generally known in the television industry that interference between two or more co-channel television stations is reduced if their picture carrier frequencies are offset by a fixed amount and if the difference frequency is held constant with a very small tolerance. For optimum results the offset frequency must be an even multiple of the frame frequency and this offset must be held constant within plus or minus five hertz per station.

The RCA Precise Frequency Control System TFC-1B supplies the equipment necessary to control the carrier frequency of one station with a typical stability of $\pm 4 \times 10^{-9}$ over a 30 day period. The guaranteed stability is $\pm 5 \times 10^{-10}$ over a 24 hour period after 30 days of continuous operation. This stability adequately meets requirements for carrier stability to gain the benefits of reduction in co-channel interference.

It is desirable to be able to determine the exact offset frequency between any two participating stations at least once per month. The method would be to precisely measure the carrier frequency of each participating station with reference to the National Bureau of Standards Station WWVB operating on 60 kHz. This system will allow each station to make an independent and continuous check of its carrier frequency with reference to WWVB.

The block diagram shows the method of measurement using the basic equipment, plus the measuring equipment.

The basic equipment (ES-560242) provides a precise car-

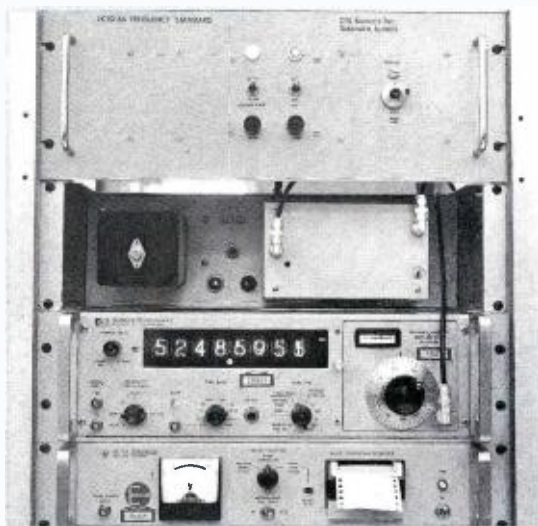

Standard Video Patch Panels Now Available With BNC Connectors

The Video Jack Panel is now available *from stock* with BNC connectors. This panel does not include the BNC mating connectors required to connect the cables to the rear of the panel. Any BNC cable connector may be used, but recommended is the single crimp connector, available from RCA in sets of 10. This connector was designed expressly for use with MI-13325 Dual Shielded Coaxial Cable.

The standard Video Jack Panel with UHF connectors will be continued in the line indefinitely. However, the UHF cable connectors for connecting the cables to the panel are no longer included. Instead UHF connectors of the single crimp variety are available from RCA in sets of 10. These connectors also are expressly designed for use with MI-13325 Dual Shielded Coaxial Cable. Special adaptors are no longer required. Tools for these single crimp connectors are also available. These tools and connectors are tremendous labor saving devices in any video system installation.

Ordering information is as follows.

MI Number	Description
26199	Video Patch Panel, BNC
556673-10	BNC Connectors, Set of 10
556674	BNC Crimping Tool
26219-A	Video Patch Panel, UHF
556670-10	UHF Connectors, Set of 10
556671	UHF Crimping Tool

Incidentally, the Self-Normaling Video Jack Panel equipment will be available indefinitely.

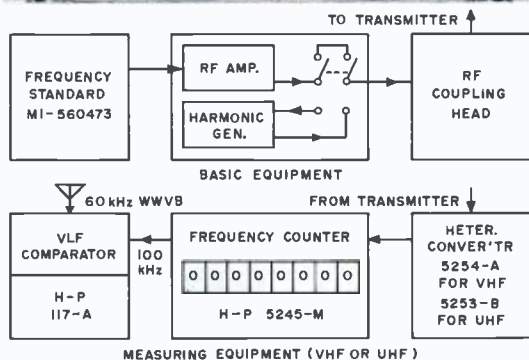

rier control system to replace the crystal of any RCA VHF or UHF transmitter, and can be adapted to most other makes of TV transmitters. For measuring equipment add option VHF or UHF.

Option VHF provides equipment necessary to measure carrier frequency with reference to WWVB to an accuracy of one hertz or better. Also provides a highly stable frequency counter which can be used for other RF measurements from 0.1 Hz to 500 MHz with reference to WWVB.

Option UHF provides equipment necessary to measure carrier frequency with reference to WWVB to an accuracy of one hertz or better. Also provides a highly stable frequency counter which can be used for other RF measurements from 500 MHz to 3000 MHz with reference to WWVB.

BCS-5000 Inter-Com System

The RCA Intercommunication System, Type BCS-5000, consists of a series of solid-state modules that may be used in various combinations to fabricate almost any size inter-com system for radio and television.

The modules include microphone preamplifiers, solid-state switching matrix, coupling amplifiers, monitor amplifiers, power supplies, control panels and auxiliary equipment such as microphones, speakers and mounting hardware.

The heart of the system is a group of these modules centrally located in a standard 19 inch rack, plus at least two or more control panels that include microphones, speakers and/or headsets. All systems are designed to meet the individual customer requirements. All of the modules are constructed on printed circuit boards, which plug into pre-wired frames. This makes it practical to expand the system in the future. As a result of the electrical and mechanical design, it requires considerably less rack mounting space than that required by comparable systems.

Products in the News

BC-18A Console

The BC-18A is a self-contained 8-mixer audio console for AM-FM-TV and auditorium applications. The console features pushbutton selection of input sources, Daven step attenuators, high-quality components, 10-watt monitor amplifier, self-contained power supply and is completely solid state.

The console incorporates 8 Daven step attenuators with cue position as mixer pots. Input selection is by a row of Centralab PB-20 pushbutton switches. Mixers 1, 2, 3 and 4 are wired with 3 microphone inputs and 1 hi-level input. Provision is made to change one of the microphone inputs on each mixer to hi-level. Mixers 4 through 8 are wired as hi-level inputs and also contain pushbutton selection of four sources. Mixers 7 and 8 are tied into the remote program cue/talkback bus and can be switched to the output of the audition channel or monitored through the cue speaker. Output of the program channel is +18 dBm after a 6 dB isolation pad.



BC-15A Console

The BC-15A is a self contained 5-mixer audio console for AM-FM-TV and auditorium applications. The console features pushbutton selection of input sources, Daven step attenuators, high-quality components, 10-watt monitor amplifier, self-contained power supply and is completely solid state.

The console incorporates 5 Daven step attenuators with cue position as mixer pots. Input selection is by a row of Centralab PB-20 pushbutton switches. Mixers 1, 2 and 3 are wired with three microphone inputs and one hi-level input. Provision is made to change one of the microphone inputs on each mixer to hi-level. Mixers 4 and 5 are wired as hi-level inputs and also contain pushbutton selection of four sources. The console contains a remote program cue/talkback bus and can be switched to the output of the audition channel or monitored through the cue speaker. Output of the program channel is +18 dBm after a 6 dB isolation pad.



Standard Switcher Packages for Local Productions

RCA now offers a new combination of standard switching systems for stations seeking more efficient utilization of their studio equipment. These systems use the TS-51 solid-state, vertical-interval, self-latching video switcher, which is operated from momentary pushbuttons. Standard TS-51 systems are available for all switching functions as follows:

Production Switching Systems

- System 7—11 inputs to 4 outputs, 1 mixer.
- System 10—16 inputs to 4 outputs, 1 mixer and special effects.
- System 14—16 inputs to 4 outputs, 2 mixers with dual re-entry and effects transfer, transition logic and cutbar operation.
- System 16—16 inputs to 8 outputs, 2 mixers with dual re-entry and effects transfer.
- System 22—16 inputs to 4 outputs, 2 mixers with dual re-entry and effects transfer, manual bypass of mixer 2.
- System 26—16 inputs to 8 outputs, 2 mixers with 2 special effects and 2 chroma key inputs.

Input Expansion Systems for Production Switchers

- System 24—Provides 12 additional inputs for 4-output systems 10, 14, 20, and 22.
- System 28—Provides 12 additional inputs for 8-output systems 16 and 26.

Master Control Switching Systems

- System 7—11 inputs to 4 outputs, 1 mixer.
- System 10—16 inputs to 4 outputs, 1 mixer and special effects.
- System 20—16 inputs to 4 outputs, 1 mixer with transition logic and cutbar operation.

Distribution Switching Systems

- System 1—11 inputs to 4 outputs.
- System 2—16 inputs to 4 outputs.
- System 3—11 inputs to 8 outputs.
- System 4—16 inputs to 8 outputs.
- System 5—11 inputs to 12 outputs.
- System 6—16 inputs to 12 outputs.

Audio Follow Video Systems

- Audio Systems A1 thru A6.
- Audio System A20.
- Audio System A710.

For stations now using a single video switcher, which is usually tied up by master control functions when on air, addition of a TS-51 constitutes a convenient station package. An ideal combination, for example, consists of System 14 for Studio Production combined with System 20/A20 for Master Control. This permits the station to do local production work while at the same time sustaining its transmitter feed.

This *master control switcher* is designed for efficient one-man operation. The combined system enables stations to use



their live camera and VTR machines productively rather than have them lie idle. Description of each switcher follows:

The TS-51 System 14 Video Switcher provides dual-reentry, by switchable effects, of two mixers with dual function program and preview rows. An automatic bypass of mixer 2 allows the same rows to be used as program and preview selectors. Thus a four bus switcher can provide essentially all of the programming normally associated with a larger six bus system. TS-51 System 14 provides 16 inputs to 4 outputs, dual reentry, 2 TA-60B mixers, a TE-60B special effects generator with effects transfer, cutbar operation, transition logic, and manual non-synchronous inhibit.

The TS-51 System 20 Master Control Switcher provides switching and mixing facilities for use at Master Control. An automatic bypass of the mixer allows the same rows feeding the mixer to be used as program and preview selectors. The same transition logic circuits are incorporated as in System 14. In addition to the program and preset rows, two other rows are provided for separate preview and for auxiliary monitoring. TS-51 System 20 provides 16 inputs to 4 outputs, 1 TA-60B mixer with transition logic, cutbar operation, and manual non-synchronous inhibit.

The A20 Audio Switching System contains a 7 x 8½ inch panel that is designed to mount into the System 20 switcher panel for convenience of one man operation. System A20 consists of 14 audio-follow-video inputs plus black, and 6 audio-only inputs, plus off. Audio-follow-video crosspoints follow the program row crosspoints of System 20. There are, in addition, 6 audio-only inputs for switching and mixing sources, such as audio cartridge tape, reel tape, announcer, mixing console, or turntable.

Solid-State AM Oscillator Buffer

This crystal oscillator is a direct replacement for the MI-27632A Tube Type Oscillator Buffer in 1-5- and 10-KW AM Transmitters of the BTA series (1R, 5T, 5U, 10U).

The solid state oscillator MI-27592 includes buffer amplifier on removable panel with 2 temperature controlled plug-in crystals—an operating and a standby crystal. Either crystal

can be switched instantaneously from operating to standby without retuning. This has the advantage of putting a heated standby crystal into operation without requiring an additional oscillator. A relay switching arrangement permits crystal change through a front panel switch without loss of air time when the transmitter is being operated remotely.

The temperature-controlled crystals are not affected by ambient temperatures because they are maintained at a high temperature by individual 14-watt thermostatically-controlled heaters. The crystal units will remain constant within ± 5 hertz. This property makes them ideal for silicon-rectifier-equipped transmitters in that the combination of the two permits transmitter operation in unheated, indoor surroundings in temperatures down to -40°F .

Installation of the Crystal Oscillator consists of merely placing it in proper position, tightening six thumbscrews, then plugging in connector and output lead.

Economy Zoom Lens for TK-44A

This new RT-H F-22 costs much less than commonly used broadcast lenses. It's an $f/2.8$ lens that zooms from 20 to 200 mm with the same resolution gotten from Varotal VRM. It features sharp focus down to four feet from subject to lens, 2-speed zoom with control cables, and NTSI all-in-one pan-focus handle. Eleven inches long, it weighs 25 pounds.

The lower price is made possible by the f-stop slower $f/2.8$ relative aperture, and elimination of provision for range extenders. When cost is a major consideration and where adequate light levels are available and the ability to provide extreme close-ups is not required, the F-22 lens will perform admirably.

Stereo and Monaural Multicartridge Tape Playback Systems

Two new multicartridge tape playback systems, the RT-16 and RT-26, are now available for the broadcaster. In both mono and stereo versions, these systems provide an economical approach for random access to as many as twelve cartridge decks while meeting or exceeding all NAB specifications.

The RT-16 contains six playback decks while the RT-26 contains twelve decks. Both systems feature the latest advances in solid-state circuitry, as typified by the elimination of mechanical relays and the use of logic circuitry.

The basic system is provided with a standard 1000-Hertz stop cue and a separate -20 dBm output for each tape deck. Standard NAB cue tones of 150 Hertz and 8000 Hertz are also available, as are audio switching, 150/600 ohm balanced output transformer, and $+40$ dBm playback amplifier.

RCA service keeps all your AM, FM, TV equipment in top condition

TAKE ADVANTAGE OF THE FOLLOWING SERVICES OFFERED BY RCA:

- Video Tape Recorder Service • TV Camera Overhaul
• TV Transmitter Overhaul • Installation Supervision
• Microphone and Pick-Up Repairs • Transmitter Performance Measurements • Antenna Inspection Measurements
• Console Repairs • Microwave Service • TV Projector Service
• Custom Fabrication • Teletypewriter Maintenance

Your audience demands a superior signal which requires top performance from all your station equipment. RCA Broadcast Service is planned to assure you of meeting this objective. More than 30 years in the broadcast industry have provided a background of solid service experience. This is the type of protection broadcasters have relied on for years, the kind of protection you can count on . . . contract or per-call . . . from the experts in the service business, RCA Service Company. To guard performance of all your equipment . . . simply telephone one of the following field offices: Chicago (WE 9-6117), Phila. (HO 7-3300). Or contact Technical Products Service, RCA Service Company, A Division of RCA, Bldg. 204-2, Camden, N. J. 08101.





New Highband VHF Transmitter TT-35FH

The TT-35FH... the highband VHF transmitter of the future... available today. This 35-kW transmitter is designed for remote operation... and will provide the best color signal in town. Color that captivates your audience... from a solid state transmitter that just won't quit.

Imagine... almost no transmitter off-air time... what a savings!! The TT-35FH is actually two transmitters—designed as one unit... if either quits the other keeps you on the air... and your audience in the primary coverage area probably won't know the difference.

The TT-35FH is reliable solid state with only 6 tubes and 2 tube types. It modulates at high level, with only two tuned linear amplifiers—plus signal shaping at output—to assure signal integrity. An extra margin of safety is achieved by conservative design—with circuits and components operating well below design ratings.

The TT-35FH is far ahead of current transmitters. It has motor-driven controls and remote metering—is ready for full remote control and automatic logging... and is even ready for eventual computer control.

And for low band VHF there's the companion 30 kW TT-30FL Transmitter with the same essential features... See your RCA Representative for details.

RCA Broadcast
Equipment

